

Fisher® ES and EAS easy-e™ Valves CL125 through CL600

Contents

Introduction	1
Scope of Manual	1
Description	2
Specifications	2
Installation	2
Maintenance	4
Packing Lubrication	5
Packing Maintenance	6
Replacing Packing	6
Trim Maintenance	11
Disassembly	11
Lapping Metal Seats	13
Valve Plug Maintenance	13
Assembly	13
ENVIRO-SEAL™ Bellows Seal and Bonnet	14
Replacing a Plain or Extension Bonnet with an ENVIRO-SEAL Bellows Seal (Stem/Bellows Assembly) and Bonnet	14
Replacement of an Installed ENVIRO-SEAL Bellows Seal (Stem/Bellows Assembly)	16
Purging the ENVIRO-SEAL Bellows Seal Bonnet	17
Parts Ordering	17
Parts Kits	17
Parts List	19

Figure 1. Fisher ES Valve with 657 Actuator



W2174-3

Introduction

Scope of Manual

This instruction manual includes installation, maintenance, and parts information for NPS 1/2 through 8 Fisher ES valves, and NPS 1 through 6 EAS valves, through CL600 ratings. Refer to separate manuals for instructions covering the actuator and accessories.

Do not install, operate, or maintain an ES valve without being fully trained and qualified in valve, actuator, and accessory installation, operation, and maintenance. To avoid personal injury or property damage, it is important to carefully read, understand, and follow all the contents of this manual, including all safety cautions and warnings. If you have any questions about these instructions, contact your Emerson Process Management sales office before proceeding.



Table 1. Specifications

<p>End Connection Styles</p> <p>Cast Iron Valves <i>Flanged:</i> CL125 flat-face or CL250 raised-face flanges per ASME B16.1</p> <p>Steel and Stainless Steel Valves <i>Flanged:</i> CL150, 300, and 600 raised-face or ring-type joint flanges per ASME B16.5 <i>Screwed or Socket Welding:</i> All available ASME B16.11 schedules that are consistent with CL600 per ASME B16.34 <i>Buttwelding:</i> Consistent with ASME B16.25</p> <p>Maximum Inlet Pressure⁽¹⁾</p> <p>Cast Iron Valves <i>Flanged:</i> Consistent with CL125B or 250B pressure-temperature ratings per ASME B16.1</p> <p>Steel and Stainless Steel Valves <i>Flanged:</i> Consistent with CL150, 300, and 600⁽²⁾ pressure-temperature ratings per ASME B16.34 <i>Screwed or Welding:</i> Consistent with CL600 pressure-temperature ratings per ASME B16.34</p>	<p>Shutoff Classifications</p> <p>See table 2</p> <p>Flow Characteristics</p> <p>Standard Cages: Linear, quick opening, or equal percentage Whisper Trim™ and WhisperFlo™ Cages: Linear</p> <p>Flow Directions</p> <p>Standard Cages: Normally up Whisper Trim and WhisperFlo Cages: Always up</p> <p>Approximate Weights</p> <table border="1"> <thead> <tr> <th rowspan="2">VALVE SIZE, NPS</th> <th colspan="2">WEIGHT</th> </tr> <tr> <th>kg</th> <th>Pounds</th> </tr> </thead> <tbody> <tr> <td>1/2 and 3/4</td> <td>11</td> <td>25</td> </tr> <tr> <td>1 and 1-1/4</td> <td>14</td> <td>30</td> </tr> <tr> <td>1-1/2</td> <td>20</td> <td>45</td> </tr> <tr> <td>2</td> <td>39</td> <td>67</td> </tr> <tr> <td>2-1/2</td> <td>45</td> <td>100</td> </tr> <tr> <td>3</td> <td>54</td> <td>125</td> </tr> <tr> <td>4</td> <td>77</td> <td>170</td> </tr> <tr> <td>6</td> <td>459</td> <td>350</td> </tr> <tr> <td>8</td> <td>408</td> <td>900</td> </tr> </tbody> </table>	VALVE SIZE, NPS	WEIGHT		kg	Pounds	1/2 and 3/4	11	25	1 and 1-1/4	14	30	1-1/2	20	45	2	39	67	2-1/2	45	100	3	54	125	4	77	170	6	459	350	8	408	900
VALVE SIZE, NPS	WEIGHT																																
	kg	Pounds																															
1/2 and 3/4	11	25																															
1 and 1-1/4	14	30																															
1-1/2	20	45																															
2	39	67																															
2-1/2	45	100																															
3	54	125																															
4	77	170																															
6	459	350																															
8	408	900																															

1. The pressure/temperature limits in this manual and any applicable standard or code limitation for the valve should not be exceeded.
2. Certain bonnet bolting material selections may require a CL600 easy-e valve assembly to be derated. Contact your Emerson Process Management sales office.

Description

These single-port valves have cage guiding, quick-change trim, and unbalanced push-down-to-close valve plug action. Valve configurations are as follows:

ES—Globe style valve (figure 1) with metal-to-metal seating as standard for all general applications over a wide range of pressure drops and temperatures, and metal-to-PTFE seating is optional for more stringent shutoff requirements.

EAS—Angle valve version of ES, used to facilitate piping or in applications where a self draining valve body is required.

Specifications

Typical specifications for these valves are shown in table 1.

Installation

⚠ WARNING

Always wear protective gloves, clothing, and eyewear when performing any installation operations to avoid personal injury.

Personal injury or equipment damage caused by sudden release of pressure may result if the valve assembly is installed where service conditions could exceed the limits given in table 1 or on the appropriate nameplates. To avoid such injury or damage, provide a relief valve for over-pressure protection as required by government or accepted industry codes and good engineering practices.

Check with your process or safety engineer for any additional measures that must be taken to protect against process media.

If installing into an existing application, also refer to the WARNING at the beginning of the Maintenance section in this instruction manual.

Table 2. Available Shutoff Classifications per ANSI/FCI 70-2 and IEC 60534-4

Seating	Shutoff Class
Metal	IV (standard)
	V
PTFE	VI

CAUTION

When ordered, the valve configuration and construction materials were selected to meet particular pressure, temperature, pressure drop, and controlled fluid conditions. Since some body/trim material combinations are limited in their pressure drop and temperature ranges, do not apply any other conditions to the valve without first contacting your Emerson Process Management sales office.

Before installing the valve, inspect the valve and pipelines for any damage and any foreign material which may cause product damage.

1. Before installing the valve, inspect the valve and associated equipment for any damage and any foreign material.
2. Make certain the valve body interior is clean, that pipelines are free of foreign material, and that the valve is oriented so that pipeline flow is in the same direction as the arrow on the side of the valve.
3. The control valve assembly may be installed in any orientation unless limited by seismic criteria. However, the normal method is with the actuator vertical above the valve. Other positions may result in uneven valve plug and cage wear, and improper operation. With some valves, the actuator may also need to be supported when it is not vertical. For more information, consult your Emerson Process Management sales office.
4. Use accepted piping and welding practices when installing the valve in the line. Internal elastomeric parts may stay in place during the welding procedure. For flanged valves, use a suitable gasket between the valve and pipeline flanges.

CAUTION

Depending on valve body materials used, post weld heat treating may be required. If so, damage to internal elastomeric and plastic parts, as well as internal metal parts is possible. Shrink-fit pieces and threaded connections may also loosen. In general, if post weld heat treating is to be performed, all trim parts should be removed. Contact your Emerson Process Management sales office for additional information.

5. With a leak-off bonnet construction, remove the pipe plugs (keys 14 and 16, figure 8) to hook up the leak-off piping. If continuous operation is required during inspection or maintenance, install a three-valve bypass around the control valve assembly.
6. If the actuator and valve are shipped separately, refer to the actuator mounting procedure in the appropriate actuator instruction manual.

⚠ WARNING

Personal injury could result from packing leakage. Valve packing was tightened before shipment; however, the packing might require some readjustment to meet specific service conditions.

Valves with ENVIRO-SEAL live-loaded packing or HIGH-SEAL Heavy-Duty live-loaded packing will not require this initial re-adjustment. See the Fisher instruction manuals titled ENVIRO-SEAL Packing System for Sliding-Stem Valves or Heavy-Duty Live-Loaded Packing System (as appropriate) for packing instructions. If you wish to convert your present packing arrangement to ENVIRO-SEAL packing, refer to the retrofit kits listed in the Parts Kits sub-section near the end of this manual.

Maintenance

Valve parts are subject to normal wear and must be inspected and replaced as necessary. Inspection and maintenance frequency depends on the severity of service conditions. This section includes instructions for packing lubrication, packing maintenance, trim maintenance, and ENVIRO-SEAL bellows seal replacement. All maintenance operations may be performed with the valve in the line.

⚠ WARNING

Avoid personal injury or damage to property from sudden release of pressure or uncontrolled process fluid. Before starting disassembly:

- Do not remove the actuator from the valve while the valve is still pressurized.
- Always wear protective gloves, clothing, and eyewear when performing any maintenance operations to avoid personal injury.
- Disconnect any operating lines providing air pressure, electric power, or a control signal to the actuator. Be sure the actuator cannot suddenly open the valve.
- Use bypass valves or completely shut off the process to isolate the valve from process pressure. Relieve process pressure on both sides of the valve. Drain the process media from both sides of the valve.
- Vent the power actuator loading pressure and relieve any actuator spring compression.
- Use lock-out procedures to be sure that the above measures stay in effect while you work on the equipment.
- The valve packing box may contain process fluids that are pressurized, *even when the valve has been removed from the pipeline*. Process fluids may spray out under pressure when removing the packing hardware or packing rings, or when loosening the packing box pipe plug.
- Check with your process or safety engineer for any additional measures that must be taken to protect against process media.

CAUTION

Follow instructions carefully to avoid damaging the product surfaces, which could result in damage to the product.

Note

Whenever a gasket seal is disturbed by removing or shifting gasketed parts, a new gasket should be installed upon reassembly. This is necessary to ensure a good gasket seal since the used gasket may not seal properly.

Note

If the valve has ENVIRO-SEAL or HIGH-SEAL live-loaded packing installed, refer to instruction manuals ENVIRO-SEAL Packing System for Sliding-Stem Valves, D101642X012, or HIGH-SEAL Live-Loaded Packing System, D101453X012, for packing

instructions. Figure 9 shows a typical HIGH-SEAL Packing system. Figures 10, 11, and 12 show typical ENVIRO-SEAL packing systems.

If the valve has an ENVIRO-SEAL bellows seal bonnet installed, refer to this manual. See the ENVIRO-SEAL Bellows Seal and Bonnet section for information on the bellows seal bonnet.

Figure 2. Optional Lubricator and Lubricator/Isolating Valve

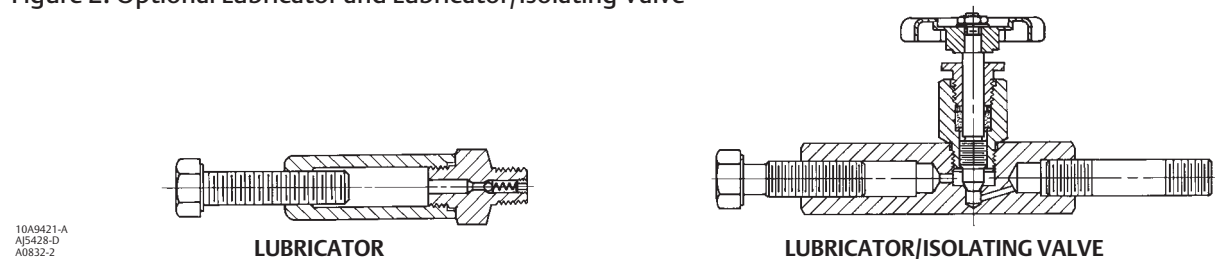

Table 3. Body-to-Bonnet Bolt Torque Guidelines

VALVE SIZE, NPS		BOLT TORQUES ^(1, 4)			
ES	EAS	SA193-B7, SA193-B8M ⁽³⁾		SA193-B8M ⁽²⁾	
		N•m	Lbf•ft	N•m	Lbf•ft
1-1/4 or less	1	129	95	64	47
1-1/2, 1-1/2 x 1, 2, or 2 x 1	2 or 2 x 1	96	71	45	33
2-1/2 or 2-1/2 x 1-1/2	3 or 3 x 1-1/2	129	95	64	47
3, 3 x 2, or 3 x 2-1/2	4 or 4 x 2	169	125	88	65
4, 4 x 2-1/2, or 4 x 3	6 or 6 x 2-1/2	271	200	156	115
6	---	549	405	366	270
8	---	746	550	529	390

1. Determined from laboratory tests.
 2. SA193-B8M annealed.
 3. SA193-B8M strain hardened.
 4. For other materials, contact your Emerson Process Management sales office for torques.

Packing Lubrication

Note

ENVIRO-SEAL or HIGH-SEAL packing does not require lubrication.

⚠ WARNING

To avoid personal injury or property damage resulting from fire or explosion, do not lubricate packing used in oxygen service or in processes with temperatures over 260°C (500°F).

If a lubricator or lubricator/isolating valve (figure 2) is provided for PTFE/composition or other packings that require lubrication, it will be installed in place of the pipe plug (key 14, figure 8). Use a good quality silicon-base lubricant. Packing used in oxygen service or in processes with temperatures over 260°C (500°F) should not be lubricated. To

operate the lubricator, simply turn the cap screw clockwise to force the lubricant into the packing box. The lubricator/isolating valve operates the same way except the isolating valve must first be opened and then closed after lubrication is completed.

Packing Maintenance

Key numbers refer to figure 3 for PTFE V-ring packing and to figure 5 for PTFE/composition packing, unless otherwise indicated.

For spring-loaded single PTFE V-ring packing, the spring (key 8, figure 3) maintains a sealing force on the packing. If leakage is noted around the packing follower (key 13, figure 3), check to be sure the shoulder on the packing follower is touching the bonnet. If the shoulder is not touching the bonnet, tighten the packing flange nuts (key 5, figure 8) until the shoulder is against the bonnet. If leakage cannot be stopped in this manner, proceed to the replacing packing procedure.

If there is undesirable packing leakage with other than spring-loaded packing, first try to limit the leakage and establish a stem seal by tightening the packing flange nuts.

If the packing is relatively new and tight on the stem, and if tightening the packing flange nuts does not stop the leakage, it is possible that the valve stem is worn or nicked so that a seal cannot be made. The surface finish of a new valve stem is critical for making a good packing seal. If the leakage comes from the outside diameter of the packing, it is possible that the leakage is caused by nicks or scratches around the packing box wall. If performing any of the following procedures, inspect the valve stem and packing box wall for nicks and scratches.

Replacing Packing

⚠ WARNING

Refer to the **WARNING** at the beginning of the Maintenance section in this instruction manual.

1. Isolate the control valve from the line pressure, and release pressure from the valve.
2. Disconnect the operating lines from the actuator and any leak-off piping from the bonnet. Disconnect the stem connector, then remove the actuator from the valve by unscrewing the yoke locknut (key 15, figure 8) or the hex nuts (key 26, figure 8).

⚠ WARNING

To avoid personal injury or property damage caused by uncontrolled movement of the bonnet, loosen the bonnet by following the instructions in the next step. Do not remove a stuck bonnet by pulling on it with equipment that can stretch or store energy in any other manner. The sudden release of stored energy can cause uncontrolled movement of the bonnet. If the cage sticks to the bonnet, proceed carefully with bonnet removal.

Note

The following step also helps to provide additional assurance that the valve body fluid pressure has been relieved.

3. Hex nuts (key 5, figure 8) attach the bonnet to the valve. Loosen these nuts or cap screws approximately 3 mm (1/8 inch). Then loosen the body-to-bonnet gasketed joint by either rocking the bonnet or prying between the bonnet and valve body. Work the prying tool around the bonnet until the bonnet loosens.

Figure 3. PTFE V-Ring Packing Arrangements for Plain and Extension Bonnets

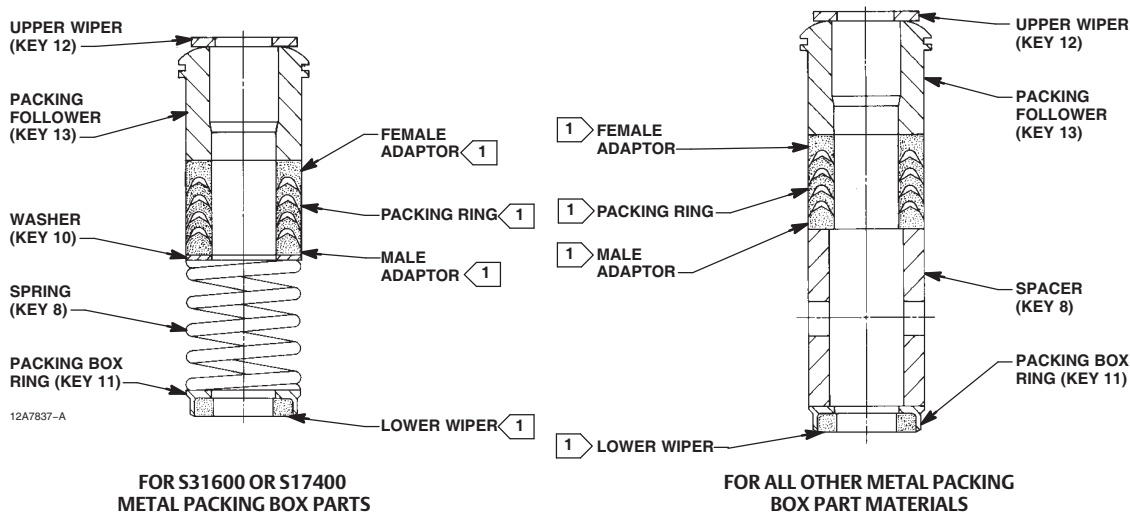

FOR S31600 OR S17400
METAL PACKING BOX PARTS

FOR ALL OTHER METAL PACKING
BOX PART MATERIALS

SINGLE ARRANGEMENTS

NOTE:
1 PART OF PACKING SET (KEY 6) (SEE TABLE IN PARTS LIST).
B2427

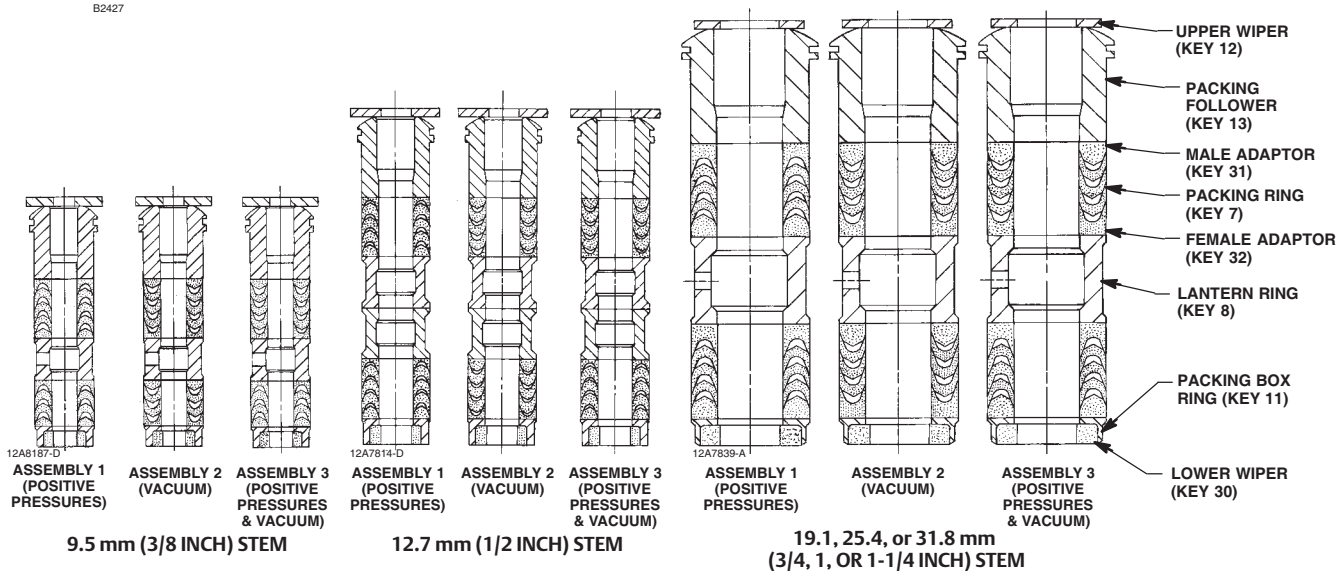

12A8187-D
ASSEMBLY 1
(POSITIVE
PRESSURES)

ASSEMBLY 2
(VACUUM)

ASSEMBLY 3
(POSITIVE
PRESSURES
& VACUUM)

12A7814-D
ASSEMBLY 1
(POSITIVE
PRESSURES)

ASSEMBLY 2
(VACUUM)

ASSEMBLY 3
(POSITIVE
PRESSURES
& VACUUM)

12A7839-A
ASSEMBLY 1
(POSITIVE
PRESSURES)

ASSEMBLY 2
(VACUUM)

ASSEMBLY 3
(POSITIVE
PRESSURES
& VACUUM)

9.5 mm (3/8 INCH) STEM

12.7 mm (1/2 INCH) STEM

19.1, 25.4, or 31.8 mm
(3/4, 1, OR 1-1/4 INCH) STEM

DOUBLE ARRANGEMENTS

B1428-3

Figure 4. PTFE Packing Arrangements for Use in ENVIRO-SEAL Bellows Seal Bonnets

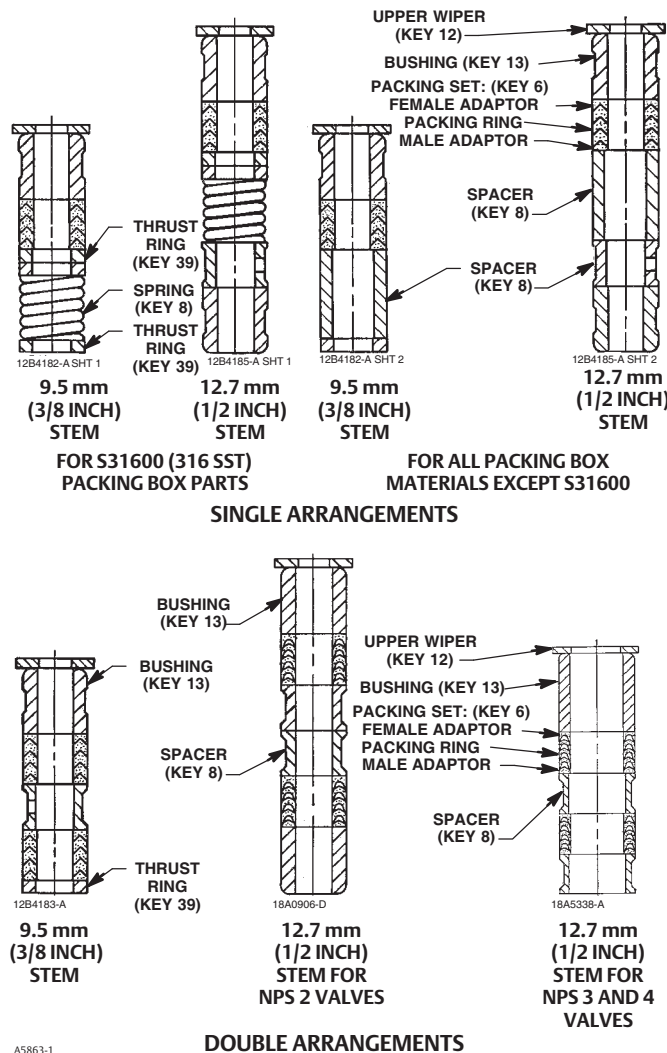

- Loosen the packing flange nuts (key 5, figure 8) so that the packing is not tight on the valve stem. Remove any travel indicator parts from the valve stem threads.

CAUTION

Avoid damage to the seating surface caused by the valve plug and stem assembly dropping from the bonnet after being lifted part way out. When lifting the bonnet, temporarily install a valve stem locknut on the valve stem. This locknut will prevent the valve plug and stem assembly from dropping out of the bonnet.

If the cage starts to lift with the bonnet, tap it with a plastic mallet, or other soft material, to be sure it stays in the valve.

- Completely remove the cap screws (not shown) or hex nuts (key 16; figure 13, 14, or 15) that bolt the bonnet and valve together and carefully lift the bonnet off.
- Remove the locknut and separate the valve plug and stem from the bonnet. Set the parts on a protective surface to prevent damage to gasket or seating surfaces.

Figure 5. Detail of PTFE/Composition Packing Arrangements for Plain and Extension Bonnets

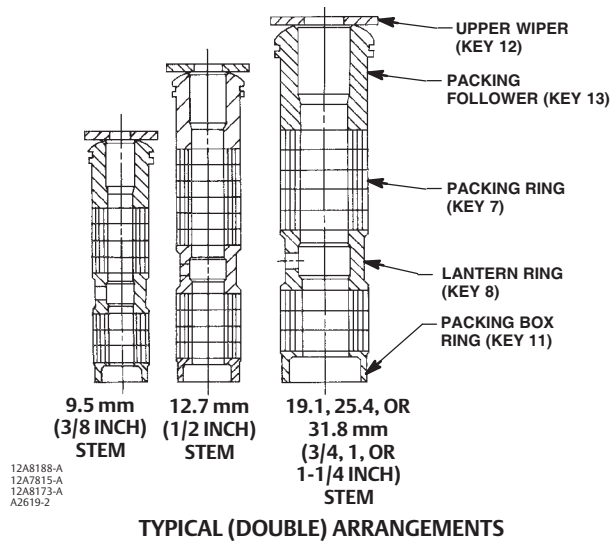

Figure 6. Double Graphite Ribbon/Filament Arrangements for use in ENVIRO-SEAL Bellows Seal Bonnets

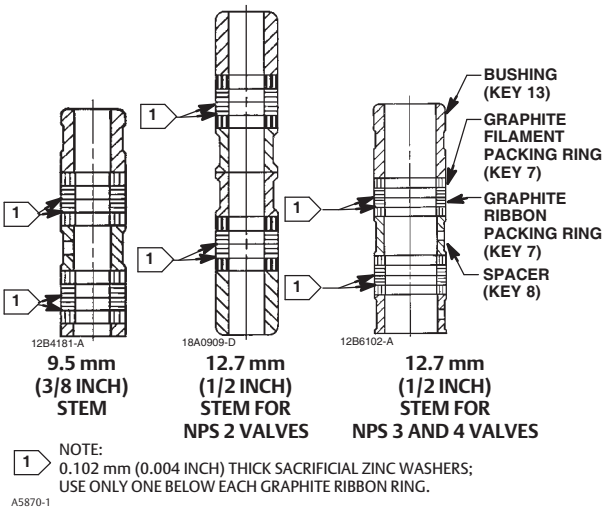
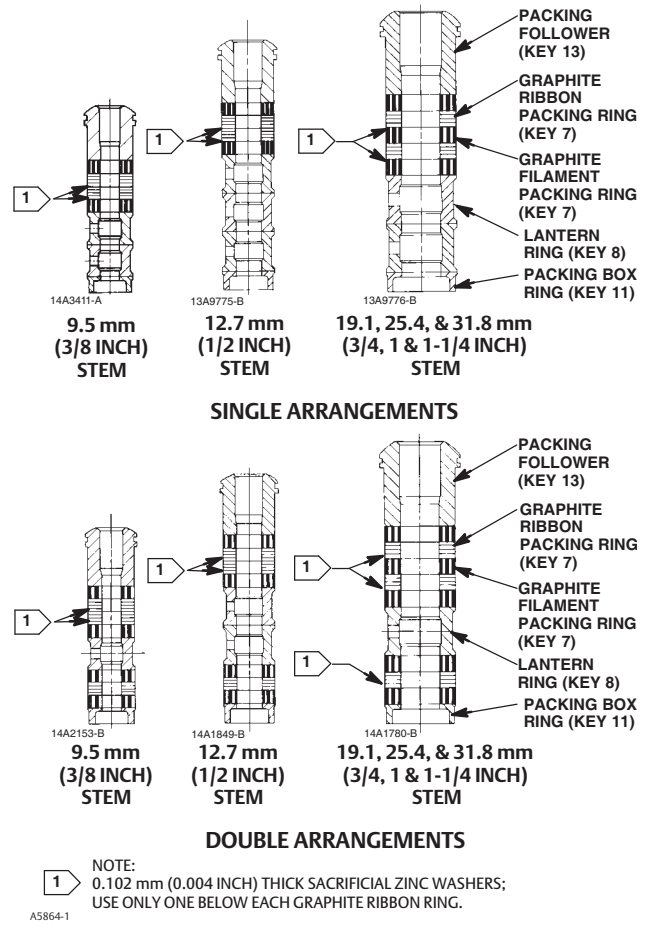

Figure 7. Detail of Graphite Ribbon/Filament Packing for Plain and Extension Bonnets



WARNING

To avoid personal injury due to leaking fluid, avoid damaging gasket sealing surfaces. The seating surface of the valve plug (key 2) is critical for proper shutoff. Protect these surfaces accordingly.

CAUTION

To prevent possible product damage, cover the opening in the valve in the following procedure to prevent foreign material from getting into the valve body cavity.

7. Remove the bonnet gasket (key 10, figure 13 through 15) and cover the opening in the valve to protect the gasket surface and prevent foreign material from getting into the valve body cavity.
8. Remove the packing flange nuts, packing flange, upper wiper, and packing follower (keys 5, 3, 12, and 13, figure 8). Carefully push out all the remaining packing parts from the valve side of the bonnet using a rounded rod or other tool that will not scratch the packing box wall. Clean the packing box and the metal packing parts.
9. Inspect the valve stem threads and packing box surfaces for any sharp edges which might cut the packing. Scratches or burrs could cause packing box leakage or damage to the new packing. If the surface condition cannot be improved by light sanding, replace the damaged parts by following the appropriate steps in the Trim Maintenance procedure.
10. Remove the covering protecting the valve body cavity and install a new bonnet gasket (key 10, figure 13 through 15), making sure the gasket seating surfaces are clean and smooth. Then slide the bonnet over the stem and onto the stud bolts (key 15, figure 13, 14, or 15) or onto the valve body cavity if cap screws (not shown) will be used instead.

Note

Proper performance of the bolting procedures in step 11 compresses the spiral wound gasket (key 12, figure 13 through 15) or load ring (key 26, figure 14) enough to both load and seal the seat ring gasket (key 13, figure 13, 14, or 15). It also compresses the outer edge of the bonnet gasket (key 10, figure 13 through 15) enough to seal the body-to-bonnet joint.

The proper bolting procedures in step 11 include--but are not limited to--ensuring that bolting threads are clean, and evenly tightening the cap screws, or the nuts onto the studs, in a crisscross pattern. Because of the boltup characteristics of spiral wound gaskets, tightening one cap screw or nut may loosen an adjacent cap screw or nut. Repeat the crisscross tightening pattern several times until each cap screw or nut is tight and the body-to-bonnet seal is made. When the operating temperature has been reached, perform this torquing procedure once again.

11. Install bolting, using proper bolting procedures during tightening so that the body-to-bonnet joint will withstand test pressures and application service conditions. The bolt torques in table 3 may be used as guidelines.
12. Install new packing and the metal packing box parts according to the appropriate arrangement in figure 3, 5, or 7. For split ring packing, alternate the positions of the splits to avoid creating a leak path. Place a smooth-edged pipe over the valve stem and gently tap each soft packing part into the packing box, being sure that air is not trapped between adjacent soft parts.
13. Slide the packing follower, upper wiper, and packing flange (keys 13, 12, and 3, figure 8) into position. Lubricate the packing flange studs (key 4, figure 8) and the faces of the packing flange nuts (key 5, figure 8). Install the packing flange nuts.
14. For **spring-loaded PTFE V-ring packing**, tighten the packing flange nuts until the shoulder on the packing follower (key 13, figure 8) contacts the bonnet.

For **ENVIRO-SEAL** or **HIGH-SEAL** live-loaded packing, refer to the note at the beginning of the Maintenance section.

For **graphite packing**, tighten the packing flange nuts to the maximum recommended torque shown in table 4. Then, loosen the packing flange nuts, and retighten them to the recommended minimum torque shown in table 4.

For **other packing types**, tighten the packing flange nuts alternately in small equal increments until one of the nuts reaches the minimum recommended torque shown in table 4. Then, tighten the remaining flange nuts until the packing flange is level and at a 90-degree angle to the valve stem.

- Mount the actuator on the valve assembly and reconnect the actuator and valve stem according to the procedure in the appropriate actuator instruction manual.

Trim Maintenance

⚠ WARNING

Refer to the **WARNING** at the beginning of the Maintenance section in this instruction manual.

CAUTION

In the following applicable procedures, to avoid damaging parts, do not grip the bellows shroud or other parts of the stem/bellows assembly. Grip only the flat areas on the stem where it extends out of the top of the bellows shroud.

Except where indicated, key numbers in this section are referenced in figure 13 for standard NPS 1/2 through 6 constructions, figure 14 for NPS 8 ES valves, figure 15 for Whisper Trim III cage detail, and figure 16 for WhisperFlo trim.

Disassembly

- Remove the actuator and the bonnet according to steps 1 through 6 of the Replacing Packing procedure of the Maintenance section.

Table 4. Recommended Torque for Packing Flange Nuts (Not for Spring-Loaded Packing)

VALVE STEM DIAMETER		PRESS-URE RATING	GRAPHITE TYPE PACKING				PTFE TYPE PACKING			
			Minimum Torque		Maximum Torque		Minimum Torque		Maximum Torque	
mm	Inches		N•m	Lbf•in	N•m	Lbf•in	N•m	Lbf•in	N•m	Lbf•in
9.5	3/8	CL125, 150	3	24	5	48	1	12	3	24
		CL250, 300	4	36	7	60	2	18	3	30
		CL600	5	48	8	72	3	24	4	36
12.7	1/2	CL125, 150	5	48	8	72	3	24	4	36
		CL250, 300	7	60	10	84	3	30	5	42
		CL600	10	84	14	120	5	42	7	60
19.1	3/4	CL125, 150	11	96	16	144	5	48	8	72
		CL250, 300	14	120	20	180	7	60	10	90
		CL600	20	180	30	264	10	90	15	132
25.4	1	CL300	24	216	37	324	12	108	16	144
		CL600	34	300	50	444	16	144	24	216
31.8	1-1/4	CL300	33	288	49	432	16	144	24	216
		CL600	45	396	66	588	22	192	33	288

⚠ WARNING

To avoid personal injury due to leaking fluid, avoid damaging gasket sealing surfaces. The surface finish of the valve stem (key 7) is critical for making a good packing seal. The inside surface of the cage or cage/baffle assembly (key 3), or cage retainer (key 31), is critical for smooth operation of the valve plug. The seating surfaces of the valve plug (key 2) and seat ring (key 9) are critical for proper shutoff. Unless inspection reveals otherwise, assume all these parts are in good condition and protect them accordingly.

2. Packing parts can be removed if desired. Replace these parts as described in the Replacing Packing procedure. Remove the load ring (key 26) from an NPS 8 ES valve, or the cage adaptor (key 4) from any restricted trim valve, and wrap it for protection.
3. Lift the valve plug and stem assembly out of the valve and set it on a protective surface. If the valve plug is to be reused, protect the valve plug seating surface to prevent scratches. On an NPS 6 ES valve with Whisper Trim III cage or WhisperFlo trim, also remove the bonnet spacer (key 32) and bonnet gasket (key 10) on top of the spacer. Then on any construction with a cage retainer (key 31), remove the cage retainer and its associated gaskets.

A Whisper Trim III and WhisperFlo trim cage retainer has two 3/8 inch-16 UNC tappings in which screws or bolts can be installed for lifting.

4. Remove the cage or cage/baffle assembly (key 3), the associated gaskets (keys 10, 11, and 12), and shim (key 51 for the ES valve, key 27 for the EAS valve). If the cage is stuck in the valve body, use a rubber mallet to strike the exposed portion of the cage at several points around its circumference.
5. Remove the seat ring or liner (key 9) or disk seat (key 22), seat ring gasket (key 13), and the seat ring adaptor (key 5) and adaptor gasket (key 14) where used in a restricted trim seat ring construction. PTFE seat constructions use a disk (key 23) sandwiched between the disk seat and disk retainer (key 21).
6. Inspect parts for wear or damage which would prevent proper operation of the valve. Replace or repair trim parts according to the following procedure for lapping metal seats or other valve plug maintenance procedures as appropriate.

Table 5. Valve Stem Connection Torque and Pin Replacement

VALVE STEM CONNECTION (VSC)		BOLT TORQUE, MINIMUM TO MAXIMUM		HOLE SIZE	
mm	Inches	N•m	Lbf•ft	mm	Inch
9.5	3/8	40-47	25-35	2.41 - 2.46	0.095 - 0.097
12.7	1/2	81-115	60-85	3.20 - 3.25	0.126 - 0.128
19.1	3/4	237-339	175-250	4.80 - 4.88	0.189 - 0.192
25.4	1	420-481	310-355	6.38 - 6.45	0.251 - 0.254
31.8	1-1/4	827-908	610-670	6.38 - 6.45	0.251 - 0.254

Table 6. Standard Material Designations

Standard Designation	Common Name or Trade Name
CoCr-A Hardfacing Alloy R30006 S17400 SST S31600 SST	CoCr-A Alloy 6 Casting 17-4PH Stainless Steel 316 Stainless Steel
S41000, S41600, CA15 WCC Carbon Steel Casting	13Cr 400-Series SST WCC

CAUTION

To avoid damaging the ENVIRO-SEAL bellows seal bonnet assembly, do not attempt to lap the metal seating surfaces. The design of the assembly prevents rotation of the stem and any forced lapping rotation will damage internal components of the ENVIRO-SEAL bellows seal bonnet.

Lapping Metal Seats

A certain amount of leakage should be expected with metal-to-metal seating in any valve body. If the leakage becomes excessive, however, the condition of the seating surfaces of the valve plug and seat ring can be improved by lapping. (Deep nicks should be machined out rather than ground out.) Use a good quality lapping compound of a mixture of 280 to 600-grit. Apply the compound to the bottom of the valve plug.

Assemble the valve to the extent that the cage and the cage retainer and bonnet spacer (if used) are in place and the bonnet is bolted to the valve body. A simple handle can be made from a piece of strap iron locked to the valve plug stem with nuts. Rotate the handle alternately in each direction to lap the seats. After lapping, remove the bonnet and clean the seat surfaces. Completely assemble as described in the assembly portion of the trim maintenance procedure and test the valve for shutoff. Repeat the lapping procedure if leakage is still excessive.

CAUTION

To avoid weakening the stem or adaptor that may cause failure in service, never reuse an old stem or adaptor with a new valve plug. Using an old stem or adaptor with a new plug requires drilling a new pin hole in the stem (or adaptor in case an ENVIRO-SEAL bellows seal bonnet is being used), which will weaken the stem. However, a used valve plug may be reused with a new stem or adaptor.

Valve Plug Maintenance

Except where indicated, key numbers are referenced in figure 13 for NPS 1/2 through 6 constructions, figure 14 for NPS 8 ES valves, figure 15 for Whisper Trim III cage detail, and figure 16 for WhisperFlo trim.

1. Remove the valve plug (key 2) according to the disassembly portion of the trim maintenance procedure.
2. To replace the valve stem (key 7), drive out the pin (key 8). Unscrew the valve plug from the stem or adaptor.
3. To replace the adaptor (key 24, figure 8) on ENVIRO-SEAL bellows seal bonnets, place the plug stem assembly and valve plug in a soft-jaw chuck or other type of vise so that the jaws grip a portion of the valve plug that is not a seating surface. Drive out or drill out the pin (key 36, figure 8). Reverse the plug stem assembly in the soft-jaw chuck or vise. Grip the flat areas on the valve stem just below the threads for the actuator/stem connection. Unscrew the valve plug/adaptor assembly (key 24, figure 8) from the valve stem assembly (key 20, figure 8).
4. Screw the stem or adaptor into the valve plug. Tighten to the torque value given in table 5. Refer to table 5 to select the proper hole size. Drill through the stem or adaptor, using the hole in the valve plug as a guide. Remove any chips or burrs and drive in a new pin to lock the assembly.
5. For ENVIRO-SEAL bellows seal bonnets, grip the flats of the stem extending out of the top of the bellows shroud with a soft-jaw chuck or other type of vise. Screw the valve plug/adaptor assembly onto the valve stem. Tighten as necessary to align the pin hole in the stem with one of the holes in the adaptor. Secure the adaptor to the stem with a new pin.

Assembly

Except where indicated, key numbers are referenced in figure 13 for standard NPS 1/2 through 6 constructions, figure 14 for NPS 8 ES valves, figure 15 for Whisper Trim III cage detail, and figure 16 for WhisperFlo trim.

1. With a restricted trim seat ring construction, install the adaptor gasket (key 14) and seat ring adaptor (key 5).
2. Install the seat ring gasket (key 13), seat ring or liner (key 9), or disk seat (key 22). With a PTFE seat construction, install the disk and disk retainer (keys 21 and 23).
3. Install the cage or cage/baffle assembly (key 3). Any rotational orientation of the cage or assembly with respect to the valve is acceptable. A Whisper Trim III cage designated by level A3, B3, or C3 may be installed with either end

- up. The level D3 cage/baffle assembly, however, must be installed with the hole pattern end next to the seat ring. If a cage retainer (key 31) is to be used, place it on top of the cage.
4. Slide the valve plug (key 2) and stem assembly, or valve plug and ENVIRO-SEAL bellows seal assembly, into the cage.
 5. Place the gaskets (key 10, or keys 11, 12 and 14, if used) and the shim (key 27 or key 51) on top of the cage or cage retainer. If there is a cage adaptor (key 4) or a bonnet spacer (key 32), set it on the cage or cage retainer gaskets and place another flat sheet gasket (key 10) on top of the adaptor or spacer. If there is only a cage retainer, place another flat sheet gasket on the retainer.
 6. With an NPS 8 ES valve, install the load ring (key 26).

CAUTION

To avoid damaging packing with the valve stem threads, use care when installing the bonnet if the packing was not removed from the bonnet.

Table 7. Recommended Torque for ENVIRO-SEAL Bellows Seal Packing Flange Nuts

VALVE SIZE NPS	VALVE STEM DIAMETER THROUGH PACKING Inch	MINIMUM TORQUE		MAXIMUM TORQUE	
		N•m	Lbf•in	N•m	Lbf•in
1/2 - 2	1/2	3	24	5	48
3 - 4	1	7	60	10	84

7. Mount the bonnet on the valve and complete assembly according to steps 10 through 14 of the Replacing Packing procedure, omitting steps 11 and 12 if new packing is not being installed, and being sure to observe the note prior to step 11.

ENVIRO-SEAL Bellows Seal and Bonnet

Replacing a Plain or Extension Bonnet with an ENVIRO-SEAL Bellows Seal (Stem/Bellows Assembly) and Bonnet

1. Remove the actuator and bonnet according to steps 1 through 6 of the Replacing Packing procedure of the Maintenance section.
2. With care, remove the valve plug and stem assembly from the valve body. If necessary, lift out the cage, also.

CAUTION

To prevent possible product damage, cover the opening in the valve in the following procedure to protect the sealing surfaces and to prevent foreign material from getting into the valve body cavity.

3. Remove and discard the existing bonnet gasket. Cover the valve body opening to protect sealing surfaces and to prevent foreign material from entering the valve body cavity.

Note

The ENVIRO-SEAL stem/bellows assembly for easy-e valves is available only with a threaded and drilled plug/adaptor/stem connection. The existing valve plug can be reused with the new stem/bellows assembly or a new plug can be installed.

4. Inspect the existing valve plug. If the plug is in good condition, it can be reused with the new ENVIRO-SEAL stem/bellows assembly. To remove the existing valve plug from the stem, first, place the existing plug stem assembly and valve plug in a soft-jaw chuck or other type of vise so that the jaws grip a portion of the valve plug that is not a seating surface. Drive out or drill out the pin (key 8).
5. Then, reverse the plug stem assembly in the soft-jaw chuck or vise. Grip the valve stem in an appropriate place and unscrew the existing plug from the valve stem.

CAUTION

When installing a valve plug on the ENVIRO-SEAL stem/bellows assembly, the valve stem must not be rotated. Damage to the bellows may result.

To avoid damaging parts, do not grip the bellows shroud or other parts of the stem/bellows assembly. Grip only the flat areas on the stem where it extends out of the top of the bellows shroud.

Note

The ENVIRO-SEAL stem/bellows assembly has a one-piece stem.

6. To attach the valve plug to the stem of the new ENVIRO-SEAL stem/bellows assembly, it is necessary to first attach the plug to the adaptor (key 24). Locate the adaptor. Notice that a hole has not been drilled in the threads where the plug screws onto the adaptor. Secure the valve plug in a soft-jaw chuck or other type of vise. Do not grip the plug on any seating surface. Position the plug in the chuck or vise for easy threading of the adaptor. Thread the adaptor into the valve plug and tighten to the appropriate torque value.
7. Select the proper size of drill bit and drill through the adaptor using the hole in the valve plug as a guide. Remove any metal chips or burrs and drive in a new pin to lock the plug/adaptor assembly together.
8. Attach the plug/adaptor assembly to the ENVIRO-SEAL stem/bellows assembly by first securing the stem/bellows assembly in a soft-jaw chuck or other type of vise so that the jaws of the chuck or vise grip the flats of the stem extending out of the top of the bellows shroud. Screw the valve plug/adaptor assembly onto the valve stem. Tighten as necessary to align the pin hole in the stem with one of the holes in the adaptor. Secure the adaptor to the stem with a new pin.
9. Inspect the seat ring (key 9) and soft seat parts (keys 21, 22, and 23). Replace, if necessary.
10. Place a new gasket (key 10) into the valve body in place of the bonnet gasket. Install the new stem/bellows assembly with valve plug/adaptor by placing it into the valve body on top of the new bellows gasket.
11. Place a new gasket (key 22) over the stem/bellows assembly. Place the new ENVIRO-SEAL bonnet over the stem/bellows assembly.
12. Properly lubricate the bonnet stud bolts. Install and tighten the bonnet hex nuts to the proper torque.
13. Install new packing and the metal packing box parts according to the appropriate arrangement in figure 3.
14. Install the packing flange. Properly lubricate the packing flange stud bolts and the faces of the packing flange nuts.

For ENVIRO-SEAL or HIGH-SEAL live-loaded packing, refer to the note at the beginning of the Maintenance section.

For **graphite packing**, tighten the packing flange nuts to the maximum recommended torque shown in table 7. Then, loosen the packing flange nuts, and retighten them to the recommended minimum torque shown in table 7.

For **other packing types**, tighten the packing flange nuts alternately in small equal increments until one of the nuts reaches the minimum recommended torque shown in table 7. Then, tighten the remaining flange nuts until the packing flange is level and at a 90-degree angle to the valve stem.

15. Install travel indicator parts, stem locknuts, and mount the actuator on the valve body according to the procedure in the appropriate actuator instruction manual.

Replacement of an Installed ENVIRO-SEAL Bellows Seal (Stem/Bellows Assembly)

1. Remove the actuator and bonnet according to steps 1 through 6 of the Replacing Packing procedure of the Maintenance section.

CAUTION

To prevent possible product damage, cover the opening in the valve in the following procedure to protect the sealing surfaces and to prevent foreign material from getting into the valve body cavity.

2. With care, remove the ENVIRO-SEAL stem/bellows assembly. If necessary, lift out the cage, also. Remove and discard the existing bonnet gasket and bellows gasket. Cover the valve body opening to protect sealing surfaces and to prevent foreign material from entering the valve body cavity.

Note

The ENVIRO-SEAL stem/bellows assembly for easy-e valves is available only with a threaded and drilled plug/adaptor/stem connection. The existing valve plug can be reused with the new stem/bellows assembly or a new plug can be installed.

3. Inspect the existing valve plug. If the plug is in good condition, it can be reused with the new stem/bellows assembly.

CAUTION

When removing/installing a valve plug on the ENVIRO-SEAL stem/bellows assembly, the valve stem must not be rotated. Damage to the bellows may result.

To avoid damaging parts, do not grip the bellows shroud or other parts of the stem/bellows assembly. Grip only the flat areas on the stem where it extends out of the top of the bellows shroud.

Note

The ENVIRO-SEAL stem/bellows assembly has a one-piece stem.

4. To remove the existing valve plug from the stem, first, place the existing plug stem assembly and valve plug in a soft-jaw chuck or other type of vise so that the jaws grip a portion of the valve plug that is not a seating surface. Drive out or drill out the pin.
5. Then, reverse the plug stem assembly in the soft-jaw chuck or vise. Grip the flat areas on the valve stem just below the threads for the actuator/stem connection. Unscrew the existing plug from the valve stem.
6. To attach either the existing valve plug or a new one to the stem of the new ENVIRO-SEAL stem/bellows assembly, it is necessary to first attach the plug to the adaptor. Locate the adaptor. Notice that a hole has not been drilled in the threads where the plug screws onto the adaptor. Secure the valve plug in a soft-jaw chuck or other type of vise. Do not grip the plug on any seating surface. Position the plug in the chuck or vise for easy threading of the adaptor. Thread the adaptor into the valve plug and tighten to the appropriate torque value.
7. Complete the installation by following steps 7 through 9 and steps 12 through 15 of the ENVIRO-SEAL Bellows Seal and Bonnet installation instructions given above.

Purging the ENVIRO-SEAL Bellows Seal Bonnet

The ENVIRO-SEAL bellows seal bonnet has been designed so that it can be purged or leak tested. Refer to figure 8 for an illustration of an ENVIRO-SEAL bellows seal bonnet, and perform the following steps for purging or leak testing.

1. Remove the two diametrically opposed pipe plugs (key 16).
2. Connect a purging fluid to one of the pipe plug connections.
3. Install appropriate piping or tubing in the other pipe plug connection to pipe away the purging fluid or to make a connection to an analyzer for leak testing.
4. When purging or leak testing has been completed, remove the piping or tubing and reinstall the pipe plugs (key 16).

Parts Ordering

Each body-bonnet assembly is assigned a serial number which can be found on the valve. This same number also appears on the actuator nameplate when the valve is shipped from the factory as part of a control valve assembly. Refer to the serial number when contacting your Emerson Process Management sales office for technical assistance. When ordering replacement parts, refer to the serial number and to the eleven-character part number for each part required from the following parts kit or parts list information.

Refer to table 6 for standard and common material designations.

WARNING

Use only genuine Fisher replacement parts. Components that are not supplied by Emerson Process Management should not, under any circumstances, be used in any Fisher valve, because they may void your warranty, might adversely affect the performance of the valve, and could cause personal injury and property damage.

Note

Neither Emerson, Emerson Process Management, nor any of their affiliated entities assumes responsibility for the selection, use, or maintenance of any product. Responsibility for the selection, use, and maintenance of any product remains with the purchaser and end user.

Parts Kits

Note

Kits do not apply to alloy C (N10276 and CW2M), Alloy 20 (N08020 and CN7M), or alloy 400 (N04400 and M35-1) trims.

Gasket Kits

Gasket Kits (includes keys 10, 11, 12, 13, and 51); plus 14 and 20 on Some Restricted Capacity Valves

DESCRIPTION	PART NUMBER
Full Capacity Valves	-198 to 593°C (-325 to 1100°F)
NPS 1/2, 3/4, 1, and 1-1/4 (NPS 1 EAS)	RGASKETX162
NPS 1-1/2 (NPS 2 EAS)	RGASKETX172
NPS 2	RGASKETX182
NPS 2-1/2 (NPS 3 EAS)	RGASKETX192
NPS 3 (NPS 4 EAS)	RGASKETX202
NPS 4 (NPS 6 EAS)	RGASKETX212
NPS 6	RGASKETX222
NPS 8	RGASKETX232
Restricted Capacity Valves w/ Metal Seating	
NPS 1-1/2 x 1 (NPS 2 x 1 EAS)	RGASKETX242
NPS 2 x 1	RGASKETX252
NPS 2-1/2 x 1-1/2 (NPS 3 x 1-1/2 EAS)	RGASKETX262
NPS 3 x 2 (NPS 4 x 2 EAS)	RGASKETX272
NPS 4 x 2-1/2 (NPS 6 x 2-1/2 EAS)	RGASKETX282

Packing Kits

Standard Packing Kits (Non Live-Loaded)

Stem Diameter, mm (Inches) Yoke Boss Diameter, mm (Inches)	9.5 (3/8) 54 (2-1/8)	12.7 (1/2) 71 (2-13/16)	19.1 (3/4) 90 (3-9/16)
PTFE (Contains keys 6, 8, 10, 11, and 12)	RPACKX00012	RPACKX00022	RPACKX00032
Double PTFE (Contains keys 6, 8, 11, and 12)	RPACKX00042	RPACKX00052	RPACKX00062
PTFE/Composition (Contains keys 7, 8, 11, and 12)	RPACKX00072	RPACKX00082	RPACKX00092
Single Graphite Ribbon/Filament (Contains keys 7 [ribbon ring], 7 [filament ring], 8, and 11)	RPACKX00102	RPACKX00112	RPACKX00122
Single Graphite Ribbon/Filament (Contains keys 7 [ribbon ring], 7 [filament ring])	RPACKX00132	RPACKX00142	RPACKX00152
Double Graphite Ribbon/Filament (Contains keys 7 [ribbon ring], 7 [filament ring], 8, and 11)	RPACKX00162	RPACKX00172	RPACKX00182

ENVIRO-SEAL Packing Retrofit Kits

Retrofit kits include parts to convert valves with existing standard bonnets to the ENVIRO-SEAL packing box construction.

Refer to figure 10 for key numbers for PTFE packing, to figure 11 for key numbers for Graphite ULF packing, and to figure 12 for key numbers for duplex packing.

PTFE kits include keys 200, 201, 211, 212, 214, 215, 217, 218, tag, and cable tie. Graphite ULF kits include keys 200, 201, 207, 208, 209, 210, 211, 212, 214, 216, 217, tag, and cable tie. Duplex kits include keys 200, 201, 207, 209, 211, 212, 214, 215, 216, 217, tag, and cable tie.

Stems and packing box constructions that do not meet Fisher stem finish specifications, dimensional tolerances, and design specifications may adversely alter the performance of this packing kit.

For part numbers of individual components in the ENVIRO-SEAL packing kits, refer to instruction manual ENVIRO-SEAL Packing System for Sliding-Stem Valves, D101642X012.

ENVIRO-SEAL Packing Retrofit Kits

PACKING MATERIAL	STEM DIAMETER AND YOKE BOSS DIAMETER, mm (INCH)				
	9.5 (3/8) 54 (2-1/8)	12.7 (1/2) 71 (2-13/16)	19.1 (3/4) 90 (3-9/16)	25.4 (1) 127 (5)	31.8 (1-1/4) 127 (5, 5H)
Double PTFE	RPACKXRT012	RPACKXRT022	RPACKXRT032	RPACKXRT042	RPACKXRT052
Graphite ULF	RPACKXRT262	RPACKXRT272	RPACKXRT282	RPACKXRT292	RPACKXRT302
Duplex	RPACKXRT212	RPACKXRT222	RPACKXRT232	RPACKXRT242	RPACKXRT252

ENVIRO-SEAL Packing Repair Kits

Repair kits include parts to replace the “soft” packing materials in valves that already have ENVIRO-SEAL packing arrangements installed or in valves that have been upgraded with ENVIRO-SEAL retrofit kits.

Refer to figure 10 for key numbers for PTFE packing, to figure 11 for key numbers for Graphite ULF packing, and to figure 12 for key numbers for duplex packing.

PTFE repair kits include keys 214, 215, and 218. Graphite ULF repair kits include keys 207, 208, 209, 210, and 214. Duplex repair kits include keys 207, 209, 214, and 215.

Stems and packing box constructions that do not meet Fisher stem finish specifications, dimensional tolerances, and design specifications may adversely alter the performance of this packing kit.

For part numbers of individual components in the ENVIRO-SEAL packing kits, refer to instruction manual ENVIRO-SEAL Packing System for Sliding-Stem Valves, D101642X012.

ENVIRO-SEAL Packing Repair Kits

Stem Diameter, mm (Inches) Yoke Boss Diameter, mm (Inches)	9.5 (3/8) 54 (2-1/8)	12.7 (1/2) 71 (2-13/16)	19.1 (3/4) 90 (3-9/16)	25.4 (1) 127 (5)	31.8 (1-1/4) 127 (5, 5H)
Double PTFE (Contains keys 214, 215, & 218)	RPACKX00192	RPACKX00202	RPACKX00212	RPACKX00222	RPACKX00232
Graphite ULF (Contains keys 207, 208, 209, 210, and 214)	RPACKX00592	RPACKX00602	RPACKX00612	RPACKX00622	RPACKX00632
Duplex (Contains keys 207, 209, 214, and 215)	RPACKX00292	RPACKX00302	RPACKX00312	RPACKX00322	RPACKX00332

Parts List

Note
Part numbers are shown for recommended spares only. For part numbers not shown, contact your Emerson Process Management sales office.

Bonnet (figures 3-12)

Key	Description	Part Number
1	Bonnet/ENVIRO-SEAL bellows seal bonnet If you need a bonnet or an ENVIRO-SEAL bellows seal bonnet as a replacement part, order by valve size and stem diameter, serial number, and desired material.	
2	Extension Bonnet Baffle	
3	Packing Flange	
3	ENVIRO-SEAL bellows seal packing flange	

Key	Description	Part Number
4	Packing Flange Stud	
4	ENVIRO-SEAL bellows seal stud bolt	
5	Packing Flange Nut	
5	ENVIRO-SEAL bellows seal hex nut	
6*	Packing set, PTFE	see following table
6*	ENVIRO-SEAL bellows seal packing set PTFE for 9.5 mm (3/8 inch) stem (1 req'd for single packing, 2 req'd for double packing)	12A9016X012
6*	ENVIRO-SEAL bellows seal packing set (cont'd) PTFE for NPS 2 with 12.7 mm (1/2 inch) stem (2 req'd for double packing) PTFE for NPS 3 and 4 with 12.7 mm (1/2 inch) stem (2 req'd for double packing)	12A9016X012
7*	Packing ring, PTFE composition	see following table
7*	ENVIRO-SEAL bellows seal packing ring for low chloride graphite ribbon/filament packing arrangement Ribbon packing ring for 9.5 mm (3/8 inch)	12A8832X012

*Recommended spare parts

Key	Description	Part Number	Key	Description	Part Number
	and NPS 2 with 12.7 mm (1/2 inch) stem (4 req'd)	18A0908X012		For NPS 3 and 4 with 12.7 mm (1/2 inch) stem (1 req'd)	
	Filament packing ring for 9.5 mm (3/8 inch) and NPS 2 with 12.7 mm (1/2 inch) stem (4 req'd)	1P3905X0172		N10276 bushing, PTFE/glass liner	12B2715X012
	Ribbon packing ring for NPS 3 and 4 with 12.7 mm (1/2 inch) stem (4 req'd)	18A0918X012		N10276 bushing, PTFE/carbon liner	12B2715X042
	Filament packing ring for NPS 3 and 4 with 12.7 mm (1/2 inch) stem (4 req'd)	14A0915X042	14	Pipe Plug for 1/4 NPT Tapping in Packing Box	
8	Spring		14	Lubricator	
8	Lantern ring		14	Lubricator/Isolating Valve	
8	ENVIRO-SEAL bellows seal spring		15	Yoke Locknut	
8	ENVIRO-SEAL bellows seal spacer		15	ENVIRO-SEAL bellows seal Locknut	
10	Special washer		16	Pipe Plug for 1/2 NPT Tapped Extension Bonnets	
11*	Packing Box Ring		16	ENVIRO-SEAL bellows seal pipe plug	
	9.5 mm (3/8 inch) stem, 316 stainless steel	1J873135072	20*	ENVIRO-SEAL bellows seal stem/bellows assembly	
	12.7 mm (1/2 inch) stem, 316 stainless steel	1J873235072		1 Ply Bellows	
	19.1 mm (3/4 inch) stem, 316 stainless steel	1J873335072		S31600 trim mat'l, N06625 bellows mat'l	
	25.4 mm (1 inch) stem, 17-4PH stainless steel	1J873435072		NPS 1 w/ 9.5 mm (3/8 inch) stem	32B4224X012
	31.8 mm (1-1/4 inch) stem, 17-4PH stainless steel	1J873535072		NPS 1-1/2 w/ 9.5 mm (3/8 inch) stem	32B4225X012
12*	Upper Wiper, felt			NPS 2 w/ 12.7 mm (1/2 inch) stem	32B4226X012
	9.5 mm (3/8 inch) stem	1J872606332		NPS 3 w/ 12.7 mm (1/2 inch) stem	32B4227X012
	12.7 mm (1/2 inch) stem	1J872706332		NPS 4 w/ 12.7 mm (1/2 inch) stem	32B4228X012
	19.1 mm (3/4 inch) stem	1J872806332		N06022 trim mat'l, N06022 bellows mat'l	
	25.4 mm (1 inch) stem	1J872906332		NPS 1 w/ 9.5 mm (3/8 inch) stem	32B4224X022
	31.8 mm (1-1/4 inch) stem	1J873006332		NPS 1-1/2 w/ 9.5 mm (3/8 inch) stem	32B4225X022
12*	ENVIRO-SEAL bellows seal upper wiper			NPS 2 w/ 12.7 mm (1/2 inch) stem	32B4226X022
	For 9.5 mm (3/8 inch) and NPS 2 with 12.7 mm (1/2 inch) stem	18A0868X012		NPS 3 w/ 12.7 mm (1/2 inch) stem	32B4227X022
	For NPS 3 and 4 with 12.7 mm (1/2 inch) stem	18A0870X012		NPS 4 w/ 12.7 mm (1/2 inch) stem	32B4228X022
13*	Packing Follower, 316 stainless steel			2 Ply Bellows	
	9.5 mm (3/8 inch) stem	1E943935072		S31600 trim mat'l, N06625 bellows mat'l	
	12.7 mm (1/2 inch) stem	1E944335072		NPS 1 w/ 9.5 mm (3/8 inch) stem	32B4224X032
	19.1 mm (3/4 inch) stem	1E944735072		NPS 1-1/2 w/ 9.5 mm (3/8 inch) stem	32B4225X032
	25.4 mm (1 inch) stem	1H982335072		NPS 2 w/ 12.7 mm (1/2 inch) stem	32B4226X032
	31.8 mm (1-1/4 inch) stem	1H998435072		NPS 3 w/ 12.7 mm (1/2 inch) stem	32B4227X032
13*	ENVIRO-SEAL bellows seal bushing			NPS 4 w/ 12.7 mm (1/2 inch) stem	32B4228X032
	For 9.5 mm (3/8 inch) stem (1 req'd), for NPS 2 with 12.7 mm (1/2 inch) stem (2 req'd)			N06022 trim mat'l, N06022 bellows mat'l	
	S31600/PTFE	18A0820X012		NPS 1 w/ 9.5 mm (3/8 inch) stem	32B4224X042
	R30006	18A0819X012		NPS 1-1/2 w/ 9.5 mm (3/8 inch) stem	32B4225X042
	S31600/Cr Ct	11B1155X012		NPS 2 w/ 12.7 mm (1/2 inch) stem	32B4226X042
	For NPS 3 and 4 with 12.7 mm (1/2 inch) stem (1 req'd)			NPS 3 w/ 12.7 mm (1/2 inch) stem	32B4227X042
	S31600/PTFE	18A0824X012		NPS 4 w/ 12.7 mm (1/2 inch) stem	32B4228X042
	R30006	18A0823X012	22*	ENVIRO-SEAL bellows seal bonnet gasket (graphite/S31600)	
	S31600/Cr Ct	11B1157X012		NPS 1/2 through 1-1/4	12B6316X022
13*	ENVIRO-SEAL bellows seal bushing/liner			NPS 1-1/2	12B6317X022
	For 9.5 mm (3/8 inch) stem (1 req'd), for NPS 2 with 12.7 mm (1/2 inch) stem (2 req'd)			NPS 2	12B6318X022
	N10276 bushing, PTFE/glass liner	12B2713X012		NPS 3	12B6319X022
	N10276 bushing, PTFE/carbon liner	12B2713X042		NPS 4	12B6320X022
			24	ENVIRO-SEAL bellows seal adaptor	
			25	Cap Screw for 127 mm (5 inch) yoke boss	
			26	Hex Nut for 127 mm (5 inch) Yoke Boss	
			27	Pipe Nipple for Lubricator/Isolating Valve	
			28	ENVIRO-SEAL bellows seal nameplate, warning	
			29	ENVIRO-SEAL bellows seal drive screw	
			34	Lubricant, anti-seize	
			36	ENVIRO-SEAL bellows seal pin	
			37	ENVIRO-SEAL bellows seal warning tag	
			38	ENVIRO-SEAL bellows seal tie	
			39	ENVIRO-SEAL bellows seal thrust ring	

Figure 8. Typical Bonnets

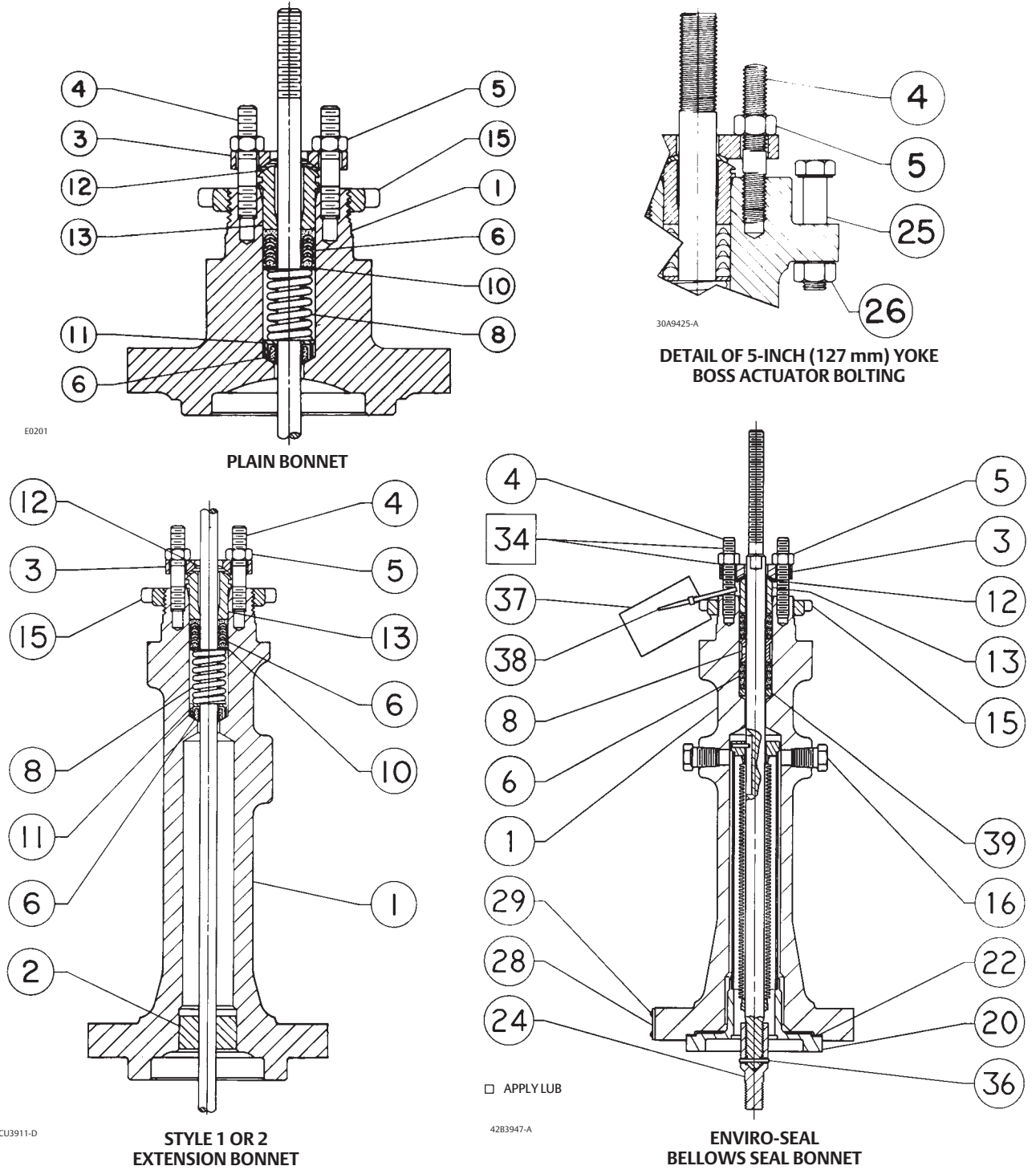
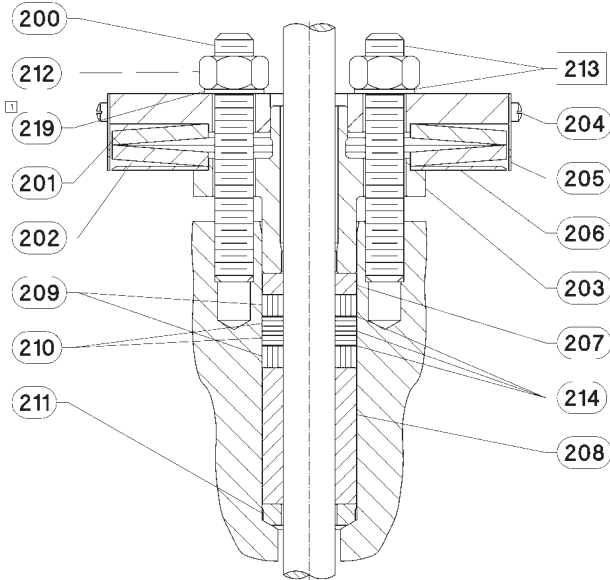

Figure 9. Typical HIGH-SEAL Graphite ULF Packing System



1. FIND NUMBER 219 NOT REQUIRED WITH 3/8 INCH STEM

39B4153-A

Figure 11. Typical ENVIRO-SEAL Packing System with Graphite ULF Packing

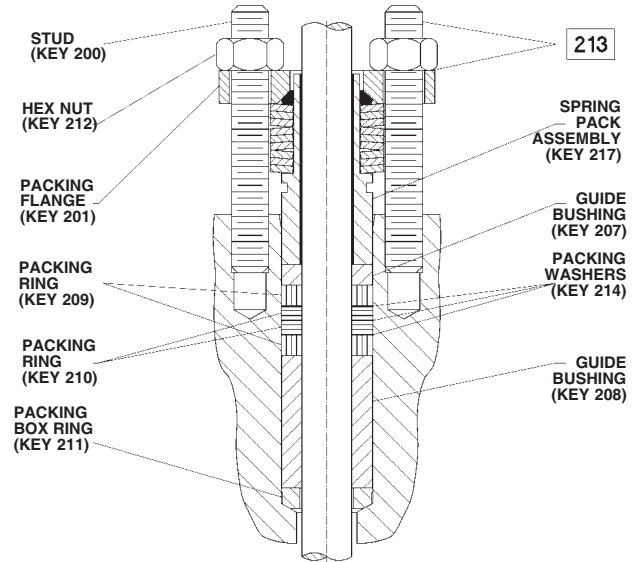

39B4612/A

Figure 10. Typical ENVIRO-SEAL Packing System with PTFE Packing

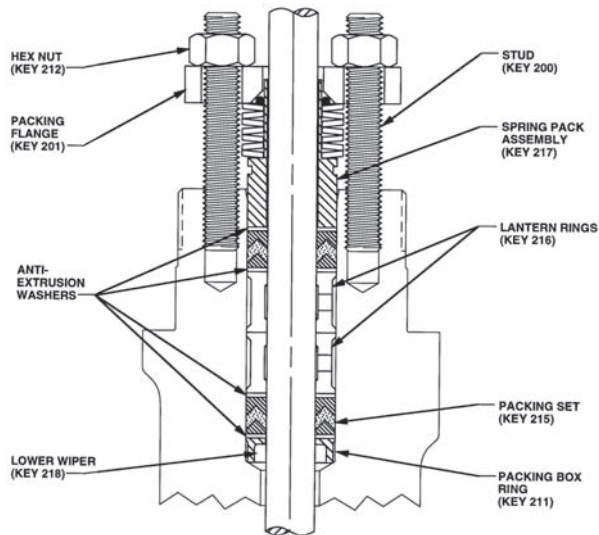

A6297-1

Figure 12. Typical ENVIRO-SEAL Packing System with Duplex Packing

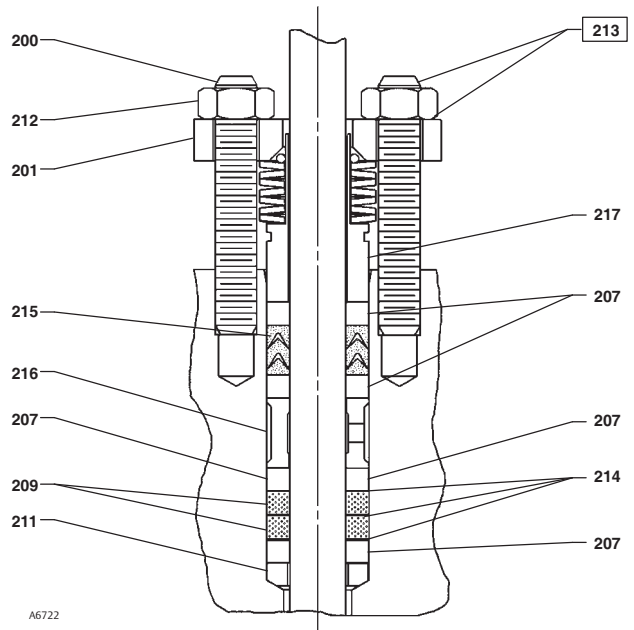

A6722

Keys 6*, 7*, 8, and 10 Packing Box Parts⁽¹⁾

DESCRIPTION		KEY NO.	STEM DIAMETER, INCHES (mm)					
			9.5 (3/8)	12.7 (1/2)	19.1 (3/4)	25.4 (1)	31.8 (1-1/4)	
PTFE V-Ring Packing	Packing Set, PTFE (1 req'd for single, 2 req'd for double) ⁽²⁾	6	1R290001012	1R290201012	1R290401012	1R290601012	1R290801012	
	Spring, Stainless Steel (for single only)	8	1F125437012	1F125537012	1F125637012	1D582937012	1D387437012	
	Lantern Ring, Stainless Steel (for double only)	8	1F364135072	1J962335072	0N028435072	0U099735072	0W087135072	
	Quantity required	Double	---	1	2	1	1	1
	Special Washer, Stainless Steel (for single only)	10	1F125236042	1F125136042	1F125036042	1H982236042	1H995936042	
PTFE/Composition Packing	Packing Ring, PTFE composition	7	1F3370X0012	1E319001042	1E319101042	1D7518X0012	1D7520X0012	
	Quantity required	Double	---	7	10	8	8	8
	Lantern Ring, Stainless Steel (1 req'd)	8	1F364135072	1J962335072	0N028435072	0U099735072	0W087135072	
Graphite Ribbon/Filament	Graphite Ribbon Ring	7	1V3160X0022	1V3802X0022	1V2396X0022	1U6768X0022	1V5666X0022	
	Quantity required	Single	---	2	2	2	2	2
		Double	---	3	3	3	3	3
	Graphite Filament Ring	7	1F3370X0322	1E3190X0222	1E3191X0282	1D7518X0132	1D7520X0162	
	Quantity required	Single	---	2	2	3	3	3
		Double	---	4	4	5	5	5
	Lantern Ring	8	1F364135072	1J962335072	0N028435072	0U099735072	0W087135072	
	Quantity required	Single	---	2	3	2	2	2
Double		---	1	2	1	1	1	

1. For ENVIRO-SEAL or HIGH-SEAL packing box parts, see instruction manual ENVIRO-SEAL Packing System for Sliding-Stem Valves, D101642X012 or HIGH-SEAL Live-Loaded Packing System, D101453X012.
 2. Key 6 for double construction contains one extra Packing Ring for the 9.5 mm (3/8 inch) stem and one extra Lower Wiper for all sizes. Discard upon assembly.

Valve Body (figures 13-15)

Key	Description	Part Number
1	Valve Body If you need a valve body as a replacement part, order by valve size, serial number, and desired material.	
2*	Valve plug	see following table
3*	Cage	see following table
4	Trim adaptor	
5	Trim adaptor	
7*	Valve plug stem	see following table
8*	Pin, 316 stainless steel	
	9.5 mm (3/8 inch) stem	1B599135072
	12.7 mm (1/2 inch) stem	1B599635072
	19.1 mm (3/4 inch) stem	1F723635072
	25.4 mm (1 inch) or 31.8 mm (1-1/4 inch) stem	1D269735072
9*	Liner	see following table
9*	Seat Ring	see following table
10*	Bonnet Gasket	see following table
11*	Cage Gasket	see following table
12*	Spiral-Wound Gasket	see following table
13*	Seat Ring or Liner Gasket	see following table
14*	Adaptor Gasket	see following table
15	Cap Screw	
15	Stud	
16	Nut	
17	Pipe Plug	
18	Flow Direction Arrow	
19	Drive Screw	
20*	Adaptor Gasket	see following table
21*	Seat Disk Retainer	see following table

Key	Description	Part Number
22*	Disk Seat	see following table
23*	Disk	see following table
26	Load Ring	
27*	Shim	see following table
31*	Whisper Trim III Cage Retainer for Levels A3, B3 & C3 (NPS 6 ES only)	
	13Cr 400-Series SST	22A3255X012
	WCC steel (ENC)	22A3256X012
	316 stainless steel (ENC)	22A3256X022
	316 stainless steel w/CoCr-A bore	22A3257X012
	316 stainless steel (electrolyzed)	31A9792X012
31*	Whisper Trim III Cage retainer & Baffle Ass'y for Level D3 (NPS 6 ES only)	
	13Cr 400-Series SST retainer & steel baffle	22A3258X012
	WCC steel (ENC) retainer & steel baffle	22A3258X022
	316 stainless steel (ENC) retainer & steel baffle	22A3258X052
	316 stainless steel w/CoCr-A bore retainer & steel baffle	22A3258X032
	316 stainless steel (ENC) retainer & 316 stainless steel baffle	22A3258X042
	316 stainless steel (electrolyzed) retainer & 316 stainless steel baffle	22A3258X062
32	Whisper Trim III Bonnet Spacer	
51*	Shim	see following table
53	Nameplate	
54	Wire	

* Recommended spare parts

Figure 13. NPS 1/2 through 6 Fisher ES and EAS Valves

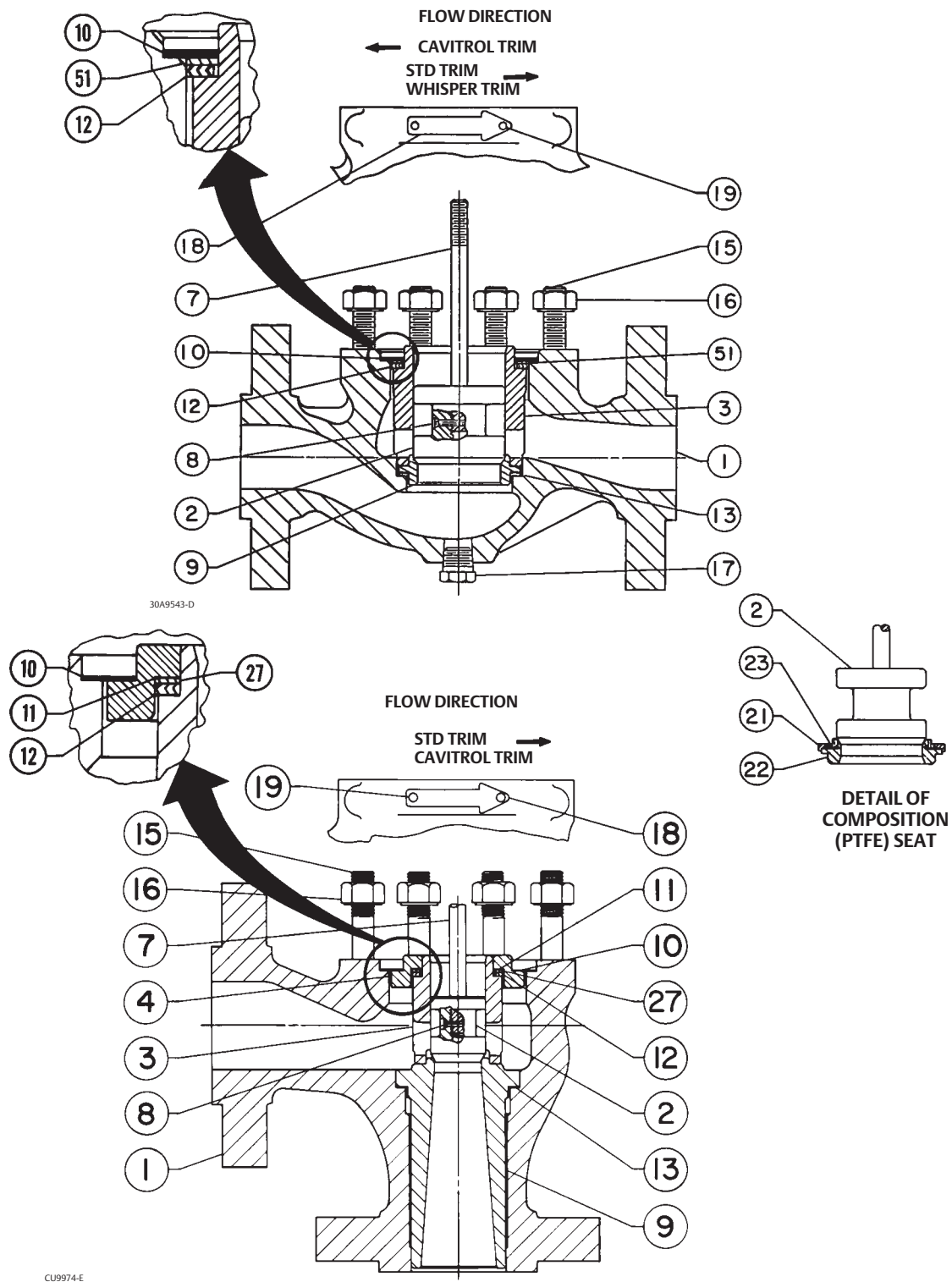

CU9974-E

Figure 14. NPS 8 Fisher ES Valve with Optional Drain Plug

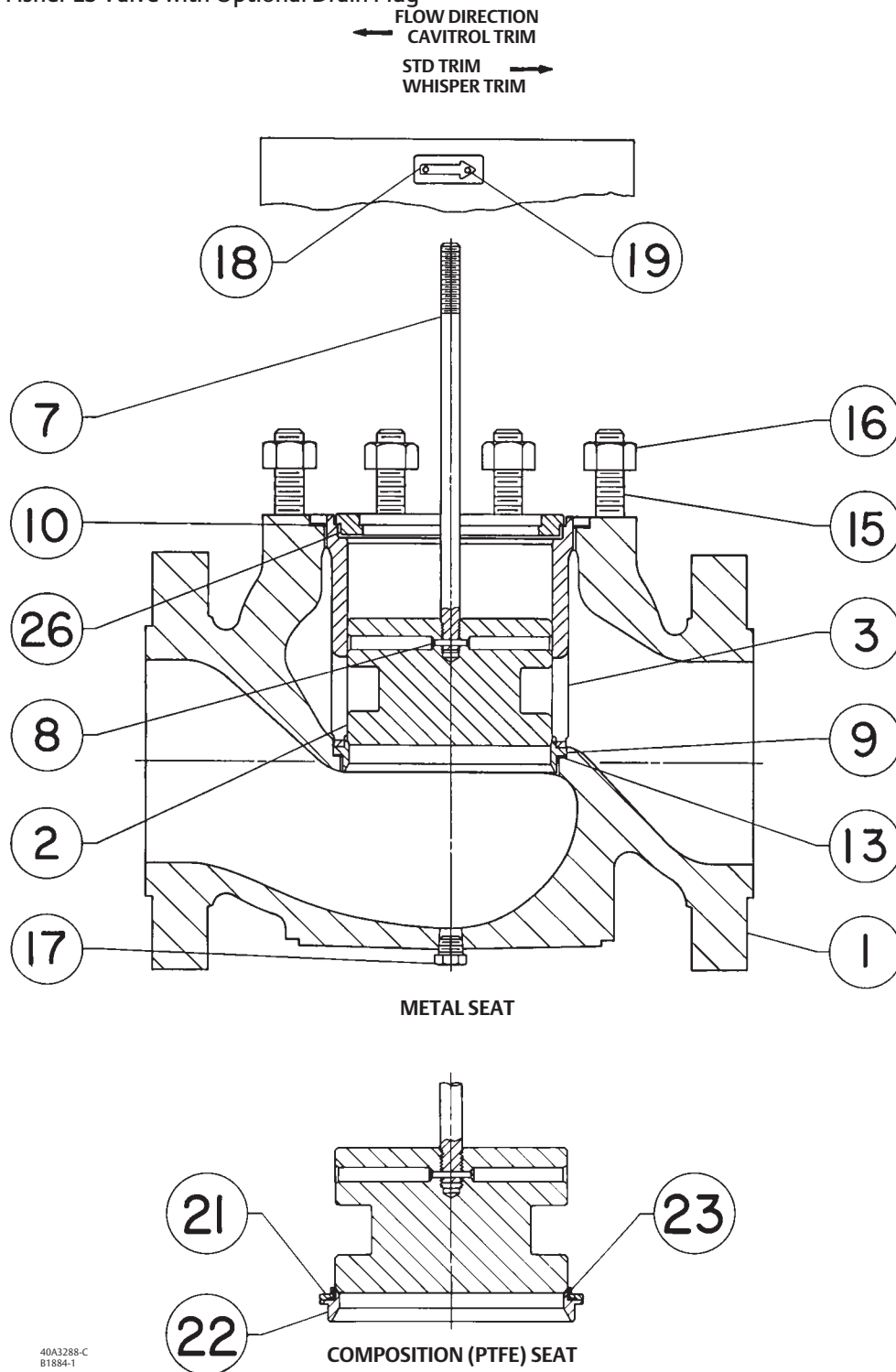

40A3288-C
B1884-1

Figure 15. Whisper Trim III Cage Detail with Optional Drain Plug

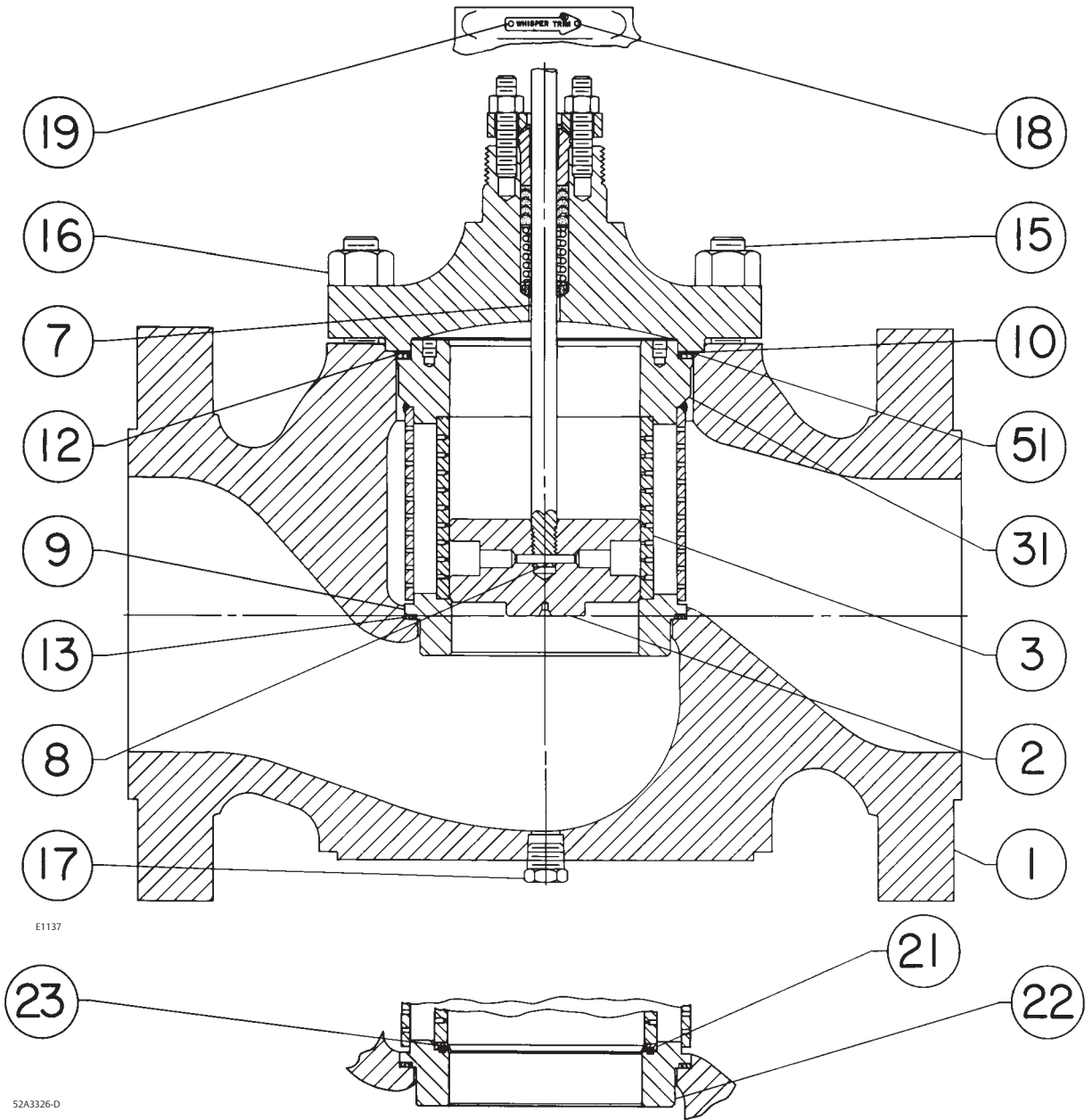

E1137

52A3326-D

Figure 16. Fisher ES Valve Assembly with WhisperFlo Cage with Optional Drain Plug

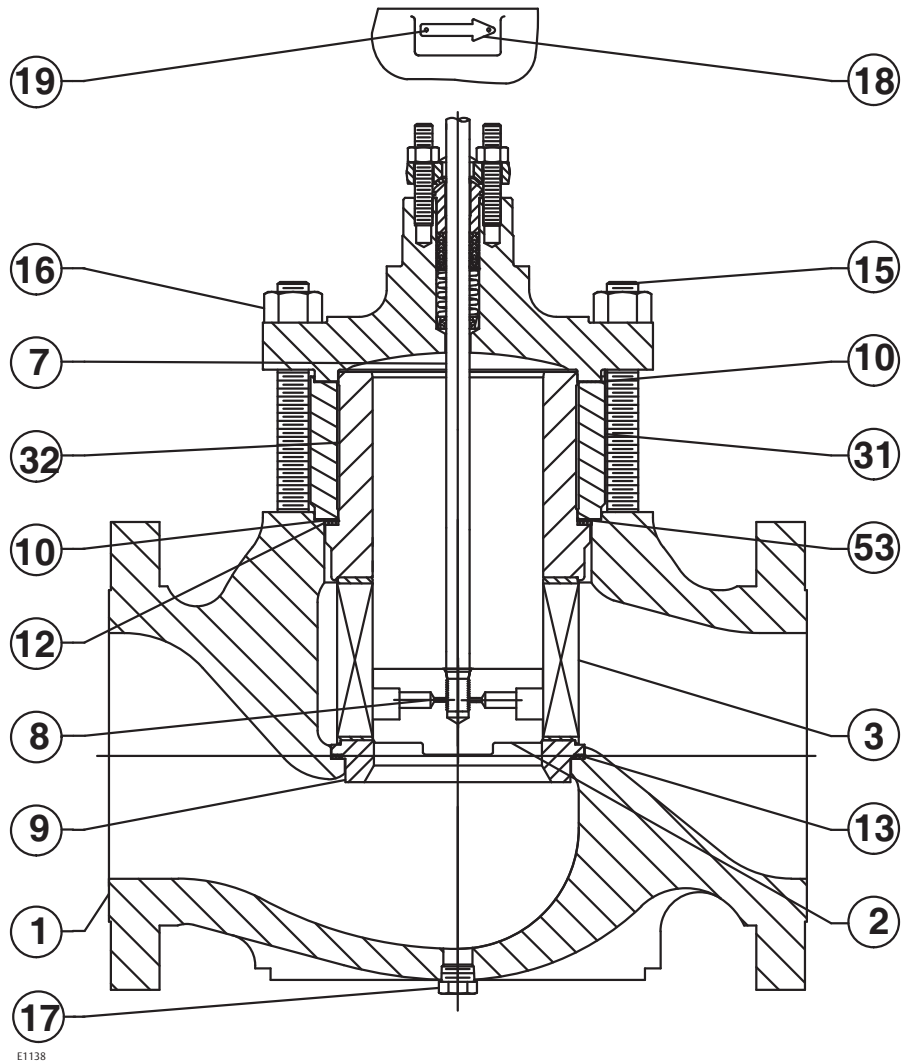

E1138

Keys 2*, 7*, and 8* Valve Plug and Stem Assembly for Plain Bonnet

VALVE SIZE, NPS		ORIFICE SIZE		STEM DIA & VSC SIZE		13Cr 400-Series Stainless Steel	316 Stainless Steel(1)	316 Stainless Steel w/ CoCr-A on Seat(1)	316 Stainless Steel w/ CoCr-A on Seat & Guide(1)	HIGH TEMPERATURE(2)
ES	EAS	mm	Inch	mm	Inch					316 Stainless Steel w/ CoCr-A on Seat & Guide
1/2 thru 2	1, 2	6.4	0.25	9.5	3/8	1U2885X0072	1U2885X0042	2U8549X0032	2V3640X0032	21A8444X022
		9.5	0.375	9.5	3/8	1U2886X0022	1U2886X0032	2U8550X0032	2V5702X00A2	21A8445X022
		12.7	0.5	9.5	3/8	1U2887X0052	1U2887X0062	2U8551X0052	2V5681X0052	21A8446X042
		19.1	0.75	9.5	3/8	1U2888X0042	1U2888X0072	2U8552X0012	2V3335X0042	21A8447X022
		25.4	1	9.5	3/8	1U2889X0072	1U2889X0102	2U8553X00F2	2V5468X0042	---
1/2 thru 2	1, 2	6.4	0.25	12.7	1/2	1U2885X0092	1U2885X0222	2U8549X0022	2V3640X0092	---
		9.5	0.375	12.7	1/2	1U2886X0262	1U2886X0232	2U8550X0062	2V5702X0032	---
		12.7	0.5	12.7	1/2	1U2887X0042	1U2887X0032	2U8551X0042	2V5681X0032	21A8446X032
		19.1	0.75	12.7	1/2	1U2888X0082	1U2888X0092	2U8552X0032	2V3335X0052	---
		25.4	1	12.7	1/2	1U2889X0062	1U2889X0052	2U8553X00G2	2V5468X0032	21A8448X022
1/2, 3/4, 1, 1-1/4	1	33.3	1.312 5	9.5 12.7	3/8 1/2	1U2161X0082 1U2161X0232	1U2161X0132 1U2161X0192	11A5200X032 ---	11A5202X032 11A5202X052	11A5204X042 ---
1-1/2	2	47.6	1.875	9.5 12.7	3/8 1/2	11A5206X042 11A5207X052	11A5206X052 11A5207X242	11A5208X022 11A5209X022	11A5210X032 11A5211X062	---
1-1/2 x 1	2 x 1	33.3	1.312 5	9.5 12.7	3/8 1/2	1U2161X0122 1U2162X0082	1U2161X0182 ---	---	11A5202X062 11A5203X042	11A5204X032 11A5205X052
2, 3 x 2	4 x 2	58.7	2.312 5	12.7 19.1	1/2 3/4	11A5214X102 11A5215X072	11A5214X122 11A5215X082	11A5216X062 ---	11A5218X042 11A5219X072	11A5220X042 11A5221X052
2 x 1	---	33.3	1.312 5	12.7	1/2	1U2162X0022	1U2162X0052	11A5201X062	11A5203X062	11A5205X032
2-1/2, 4 x 2-1/2	3, 6 x 2-1/2	73.0	2.875	12.7 19.1	1/2 3/4	11A5222X042 11A5223X052	11A5222X112 11A5223X112	11A5224X022 ---	11A5226X072 11A5227X052	---
2-1/2 x 1-1/2	3 x 1-1/2	47.6	1.875	12.7	1/2	11A5207X052	11A5207X242	11A5209X022	11A5211X062	11A5213X022
3	4	87.3	3.437 5	12.7 19.1	1/2 3/4	11A5230X082 11A5231X052	11A5230X092 11A5231X042	11A5232X022 ---	11A5234X042 11A5235X042	11A5236X042 ---
4	6	111.1	4.375	12.7 19.1	1/2 3/4	11A5238X052 11A5239X072	11A5238X072 11A5239X062	11A5241X022 ---	11A5244X032 11A5245X112	---
6	---	177.8	7	19.1	3/4	11A5250X052	11A5250X142	11A5253X022	---	---
8	---	203.2	8	19.1	3/4	21A5262X0A2	---	---	---	---

1. Not for use with 17-4PH stainless steel cages above 210°C (410°F) or CoCr-A cages above 427°C (800°F); use high temperature valve plugs for these applications.
 2. For use with 17-4PH stainless steel cages between 210°C (410°F) and 427°C (800°F) and with CoCr-A cages over 427°C (800°F), note that the letter H is stamped on top for identification.

Keys 2*, 7*, and 8* Valve Plug and Stem Assembly for Style 1 Extension Bonnet

VALVE SIZE, NPS		ORIFICE SIZE		STEM DIA & VSC SIZE		13Cr 400-Series Stainless Steel	316 Stainless Steel ⁽¹⁾	316 Stainless Steel w/ CoCr-A on Seat ⁽¹⁾	316 Stainless Steel w/ CoCr-A on Seat & Guide ⁽¹⁾	HIGH TEMPERATURE ⁽²⁾
ES	EAS	mm	Inch	mm	Inch					316 Stainless Steel w/ CoCr-A on Seat & Guide
1/2 thru 2	1, 2	6.4	0.25	9.5	3/8	1U2885X0082	---	2U8549X0042	2V3640X0042	---
		9.5	0.375	9.5	3/8	1U2886X0072	1U2886X0042	2U8550X0042	2V5702X0042	21A8445X032
		12.7	0.5	9.5	3/8	1U2887X0092	1U2887X0232	2U8551X0032	2V5681X0062	---
		19.1	0.75	9.5	3/8	1U2888X0062	1U2888X0112	2U8552X0022	---	21A8447X0B2
		25.4	1	9.5	3/8	1U2889X0082	1U2889X0112	---	2V5468X0242	21A8448X032
1/2 thru 2	1, 2	6.4	0.25	12.7	1/2	1U2885X0112	---	---	---	---
		9.5	0.375	12.7	1/2	---	---	---	---	---
		12.7	0.5	12.7	1/2	1U2887X0122	---	2U8551X0062	---	---
		19.1	0.75	12.7	1/2	1U2888X0122	---	2U8552X0052	2V3335X0122	---
		25.4	1	12.7	1/2	1U2889X0162	---	2U8553X00C2	2V5468X00C2	---
1/2, 3/4, 1, 1-1/4	1	33.3	1.3125	9.5 12.7	3/8 1/2	1U2161X0162 ---	1U2161X0262 ---	---	11A5202X082 ---	11A5204X112 11A5205X152
1-1/2	2	47.6	1.875	9.5 12.7	3/8 1/2	11A5206X062 11A5207X062	11A5206X292 ---	---	11A5210X052 11A5211X052	11A5212X022 ---
1-1/2 x 1	2 x 1	33.3	1.3125	9.5 12.7	3/8 1/2	1U2161X0212 1U2162X0242	---	---	11A5202X152 ---	11A5204X052 11A5205X072
2, 3 x 2	4 x 2	58.7	2.3125	12.7 19.1	1/2 3/4	11A5214X112 11A5215X062	---	11A5216X032 ---	11A5218X052 11A5219X042	11A5220X032 11A5221X042
2 x 1	---	33.3	1.3125	12.7	1/2	1U2162X0042	1U2162X0032	---	---	---
2-1/2, 4 x 2-1/2	3, 6 x 2-1/2	73.0	2.875	12.7 19.1	1/2 3/4	11A5222X062 11A5223X072	---	---	11A5226X032 ---	---
2-1/2 x 1-1/2	3 x 1-1/2	47.6	1.875	12.7	1/2	11A5207X062	---	---	11A5211X052	---
3	4	87.3	3.4375	12.7 19.1	1/2 3/4	11A5230X482 11A5231X152	---	---	11A5234X052 ---	---
4	6	111.1	4.375	12.7 19.1	1/2 3/4	11A5238X102 11A5239X192	11A5238X062 ---	---	---	11A5245X122 ---
6	---	177.8	7	19.1	3/4	11A5250X072	---	---	---	---
8	---	203.2	8	19.1	3/4	---	---	21A5265X022	---	---

1. Not for use with 17-4PH stainless steel cages above 210°C (410°F) or CoCr-A cages above 427°C (800°F); use high temperature valve plugs for these applications.
 2. For use with 17-4PH stainless steel cages between 210°C (410°F) and 427°C (800°F) and with CoCr-A cages over 427°C (800°F), note that the letter H is stamped on top for identification.

Keys 2* Valve Plug

VALVE SIZE, NPS		ORIFICE SIZE		STEM DIA & VSC SIZE		13Cr 400-Series Stainless Steel	316 Stainless Steel ⁽¹⁾	316 Stainless Steel w/ CoCr-A on Seat ⁽¹⁾	316 Stainless Steel w/ CoCr-A on Seat & Guide ⁽¹⁾	HIGH TEMPERATURE ⁽²⁾
ES	EAS	mm	Inch	mm	Inch					316 Stainless Steel w/ CoCr-A on Seat & Guide
1/2 thru 2	1, 2	6.4	0.25	9.5	3/8	1U288546172	1U288535072	2U854946052	2V364046062	21A8444X012
		9.5	0.375	9.5	3/8	1U288646172	1U288635072	2U855046052	2V570246062	21A8445X012
		12.7	0.5	9.5	3/8	1U288746172	1U288735072	2U855146052	2V568146062	21A8446X012
		19.1	0.75	9.5	3/8	1U288846172	1U288835072	2U855246052	2V333546062	21A8447X012
		25.4	1	9.5	3/8	1U288946172	1U288935072	2U855346052	2V546846062	21A8448X012
1/2, 3/4, 1, 1-1/4, 1-1/2 X 1	1, 2 X 1	33.3	1.3125	9.5 12.7	3/8 1/2	1U216146172 1U216246172	1U216135072 1U216235072	11A5200X012 11A5201X012	11A5202X012 11A5203X012	11A5204X012 11A5205X012
1-1/2	2	47.6	1.875	9.5 12.7	3/8 1/2	11A5206X012 11A5207X012	11A5206X022 11A5207X022	11A5208X012 11A5209X012	11A5210X012 11A5211X012	11A5212X012 11A5213X012
2, 3 x 2	4 x 2	58.7	2.3125	12.7 19.1	1/2 3/4	11A5214X012 11A5215X012	11A5214X022 11A5215X022	11A5216X012 11A5217X012	11A5218X012 11A5219X012	11A5220X012 11A5221X012
2 x 1	---	33.3	1.3125	12.7	1/2	1U216246172	1U216235072	11A5201X012	11A5203X012	11A5205X012
2-1/2, 4 x 2-1/2	3, 6 x 2-1/2	73.0	2.875	12.7 19.1	1/2 3/4	11A5222X012 11A5223X012	11A5222X022 11A5223X022	11A5224X012 11A5225X012	11A5226X012 11A5227X012	11A5228X012 11A5229X012
2-1/2 x 1-1/2	3 x 1-1/2	47.6	1.875	12.7	1/2	11A5207X012	11A5207X022	11A5209X012	11A5211X012	11A5213X012
3	4	87.3	3.4375	12.7 19.1	1/2 3/4	11A5230X012 11A5231X012	11A5230X022 11A5231X022	11A5232X012 11A5233X012	11A5234X012 11A5235X012	11A5236X012 11A5237X012
4	6	111.1	4.375	12.7 19.1 25.4	1/2 3/4 1	11A5238X012 11A5239X012 11A5240X012	11A5238X022 11A5239X022 11A5240X022	11A5241X012 11A5242X012 11A5243X012	11A5244X012 11A5245X012 11A5246X012	11A5247X012 11A5248X012 11A5249X012
6	---	177.8	7	19.1 25.4 31.8	3/4 1 1-1/4	11A5250X012 11A5251X012 11A5252X012	11A5250X022 11A5251X022 11A5252X022	11A5253X012 11A5254X012 11A5255X012	11A5256X012 11A5257X012 11A5258X012	11A5259X012 11A5260X012 11A5261X012
8	---	203.2	8	19.1 25.4 31.8	3/4 1 1-1/4	21A5262X012 21A5263X012 21A5264X012	21A5262X022 21A5263X022 21A5264X022	21A5265X012 21A5266X012 21A5267X012	21A5268X012 21A5269X012 21A5270X012	21A5271X012 21A5272X012 21A5273X012

1. Not for use with 17-4PH stainless steel cages above 210°C (410°F) or CoCr-A cages above 427°C (800°F); use high temperature valve plugs for these applications.
2. For use with 17-4PH stainless steel cages between 210°C (410°F) and 427°C (800°F) and with CoCr-A cages over 427°C (800°F), note that the letter H is stamped on top for identification.

Key 3* Quick Opening Cage

VALVE SIZE, NPS		17-4PH SST (HARDENED)	316 SST		ALLOY 6
ES	EAS		Chrome Plated	Nickel Coated	
1, 1-1/4, 1-1/2 x 1, or 2 x 1	1 or 2 x 1	2U215033272	2U691146102	2U740348932	2U215039102
1-1/2 or 2-1/2 x 1-1/2	2 or 3 x 1-1/2	2U219233272	2U691846102	2U725448932	2U219239102
2 or 3 x 2	4 x 2	2U223433272	2U692146102	2U740448932	2U223439102
2-1/2 or 4 x 2-1/2	3 or 6 x 2-1/2	2U227633272	2U692446102	2U740548932	2U227639102
3	4	2U231833272	2U692746102	2U740648932	2U231839102
4	6	2U236033272	2U693046102	2U740748932	2U236039102
6	---	2U506333272	2U693546102	2U806948932	2U506339102
8	---	20A3249X012	20A4350X012	20A5469X012	20A3249X092

Key 3* Linear Cage

VALVE SIZE, NPS		17-4PH SST (HARDENED)	316 SST		ALLOY 6
ES	EAS		Chrome Plated	Nickel Coated	
1, 1-1/4, 1-1/2 x 1, or 2 x 1	1 or 2 x 1	2U215633272	2U691746102	2U741448932	2U215639102
1-1/2 or 2-1/2 x 1-1/2	2 or 3 x 1-1/2	2U219833272	2U692046102	2U741548932	2U219839102
2 or 3 x 2	4 x 2	2U224033272	2U692346102	2U741648932	2U224039102
2-1/2 or 4 x 2-1/2	3 or 6 x 2-1/2	2U228233272	2U692646102	2U741748932	2U228239102
3	4	2U232433272	2U692946102	2U741848932	2U232439102
4	6	2U236633272	2U693346102	2U741948932	2U236639102
6	---	2U506133272	2U693846102	2U806848932	2U506139102
8	---	20A3247X012	20A4349X012	20A5468X012	20A3247X092

Key 3* Equal Percentage Cage

VALVE SIZE, NPS		17-4PH SST (HARDENED)	316 SST		ALLOY 6
ES	EAS		Chrome Plated	Nickel Coated	
1, 1-1/4, 1-1/2 x 1, or 2 x 1	1 or 2 x 1	2U215333272	2U691346102	2U740848932	2U215339102
1-1/2 or 2-1/2 x 1-1/2	2 or 3 x 1-1/2	2U219533272	2U691946102	2U740948932	2U219539102
2 or 3 x 2	4 x 2	2U223733272	2U692246102	2U741048932	2U223739102
2-1/2 or 4 x 2-1/2	3 or 6 x 2-1/2	2U227933272	2U692546102	2U741148932	2U227939102
3	4	2U232133272	2U692846102	2U741248932	2U232139102
4	6	2U236333272	2U693146102	2U741348932	2U236339102
6	---	2U505933272	2U693746102	2U806748932	2U505939102
8	---	20A3245X012	20A4348X012	20A5467X012	20A3245X092

Key 3* Micro-Flow and Micro-Flute Cage

ES VALVE SIZE, NPS	EAS VALVE SIZE, NPS	17-4PH SST (HARDENED)	316 SST		ALLOY
			Chrome Plated	Nickel Coated	
1/2, 3/4, 1, 1-1/4	1, 2 x 1	2U215033272	2U691146102	2U740348932	2U215039102
1-1/2	2	1U286733272	2U693946102	2U742048932	1U286739102
2	---	1U286933272	2U694046102	2U742148932	1U286939102

Key 3* Whisper Trim I Cage

VALVE SIZE, NPS		WHISPER TRIM I, 17-4PH SST (HARDENED)
ES	EAS	
1, 1-1/4, 1-1/2 x 1, or 2 x 1	1 or 2 x 1	2V502333272
1-1/2 or 2-1/2 x 1-1/2	2 or 3 x 1-1/2	2V502433272
2 or 3 x 2	4 x 2	2V502533272
2-1/2 or 4 x 2-1/2	3 or 6 x 2-1/2	2V502633272
3	4	2V502733272
4	6	23A8915X032
6	---	23A8913X012

Key 3* Whisper Trim III Cage (NPS 6 Fisher ES Only)

Level	13Cr 400-Series Stainless Steel	316 SST (Nickel Coated)	316 SST (Electrolized)
A3	32A3248X012	32A3251X012	32A3336X012
B3	32A3249X012	32A3252X012	32A3337X012
C3	32A3250X012	32A3253X012	32A3338X012
D3	32A6217X012	32A6220X012	32A6741X012

Key 7* Fisher ES Valve Plug Stem, 316 stainless steel (not for Whisper Trim III cage)

VALVE SIZE, NPS	STEM DIA & VSC SIZE		PLAIN BONNET ⁽³⁾				EXTENSION BONNET						
			Stem Length		Part Number	Style 1 ⁽³⁾			Style 2				
			mm	Inches		mm	Inches	mm	Inches	Part Number	mm	Inches	Part Number
Full Capacity	1/2, 3/4, 1, 1-1/4, or 1-1/2	9.5 12.7	3/8 1/2	225 300	8.875 11.8125	1U388835162 1U389035162	311 402	12.25 15.8125	1U217735162 1U217935162	405 473	15.9375 18.625	10A8823X022 1U218035162	
	2	12.7 19.1	1/2 3/4	311 372	12.25 14.625	1K586935162 1U226535162	413 483	16.25 19	1U226335162 1L400135162	614 ---	24.1875 ---	1U226435162 ---	
	2-1/2 or 3	12.7 19.1	1/2 3/4	321 381	12.625 15	1U230535162 1U230835162	421 502	16.5625 19.75	1U230635162 1U444635162	624 ---	24.5625 ---	1U230735162 ---	
	4	12.7 19.1	1/2 3/4	321 394	12.625 15.5	1U230535162 1K587735162	421 502	16.5625 19.75	1U230635162 1U444635162	624 694	24.5625 27.3125	1U230735162 1U240035162	
		25.4 ⁽¹⁾ 25.4 ⁽²⁾	1 ⁽¹⁾ 1 ⁽²⁾	464 489	18.25 19.25	1K759035162 1U217535162	---	---	---	---	---	---	
		19.1 25.4 31.8	3/4 1 1-1/4	403 499 508	15.875 19.625 20	1L996435162 1N704735162 1K415435162	511 630 656	20.125 24.8125 25.8125	1U507135162 1K785135162 1R562435162	699 ---	27.5 ---	1U524435162 ---	
8 ⁽³⁾	19.1 25.4 31.8	3/4 1 1-1/4	492 614 705	19.375 24.1875 27.4375	1K588035162 1K7891X0012 1L268835162	533 614 705	21 24.8125 29.4375	1U928235162 1K7891X0012 1L268835162	---	---	---		
	Restricted Capacity	1-1/2 x 1	9.5 12.7	3/8 1/2	241 311	9.375 12.25	1U223635162 1K586935162	324 413	12.75 16.25	1U227035162 1U226335162	418 486	16.4375 19.125	1U227235162 1U227335162
		2 x 1 or 2-1/2 x 1-1/2	12.7	1/2	300	11.8125	1U389035162	402	15.8125	1U217935162	605	23.8125	1U389335162
3 x 2		12.7 19.1	1/2 3/4	311 372	12.25 14.625	1K586935162 1U226535162	413 483	16.25 19	1U226335162 1L400135162	614 ---	24.1875 ---	1U226435162 ---	
		4 x 2-1/2	12.7 19.1	1/2 3/4	321 381	12.625 15	1U230535162 1U230835162	421 502	16.5625 19.75	1U230635162 1U444635162	624 681	24.5625 26.8125	1U230735162 1U232335162

1. 667 actuator.
 2. 657 or 585C Size 60-130 actuator.
 3. For the NPS 8 valve, the plain bonnet is standard for cast iron and WCC valves, and the style 1 bonnet is standard for CF8M valves.

Key 7* Whisper Trim III Valve Plug Stem, 316 stainless steel (NPS 6 Fisher ES only)

STEM DIA. & VSC SIZE		PLAIN BONNET	EXTENSION BONNET	
mm	Inches		Style 1	Style 2
19.1	3/4	1U341635162	1U928235162	1U6276X0012
25.4	1	1P847635162	1U627735162	---

Key 7* Fisher EAS Valve Plug Stem for Plain and Extension Bonnets

VALVE SIZE, NPS	STEM DIA & VSC SIZE		PLAIN BONNET				EXTENSION BONNET					
			Stem Length		Part Number	Style 1			Style 2			
			mm	Inches		mm	Inches	mm	Inches	Part Number	mm	Inches
Full Capacity	1 or 2	9.5	3/8	225	8.875	1U388835162	311	12.25	1U217735162	405	15.9375	1U217835162
		12.7	1/2	300	11.8125	1U389035162	402	15.8125	1U217935162	473	18.625	1U218035162
	3 or 4	12.7	1/2	321	12.625	1U230535162	421	16.5625	1U230635162	624	24.5625	1U230735162
		19.1	3/4	381	15	1U230835162	502	19.75	1U444635162	---	---	---
	6	12.7	1/2	321	12.625	1U230535162	421	16.5625	1U230635162	624	24.5625	1U230735162
		19.1	3/4	394	15.5	1K587735162	502	16.75	1U444635162	694	27.3125	1U240035162
25.4 ⁽¹⁾		1 ⁽¹⁾	464	18.25	1K759035162	---	---	---	---	---	---	
		25.4 ⁽²⁾	1 ⁽²⁾	489	19.25	1U217535162	---	---	---	---	---	
Restricted Capacity	2 x 1	9.5	3/8	241	9.375	1U223635162	324	12.75	1U227035162	418	16.4375	1U227235162
		12.7	1/2	311	12.25	1K586935162	413	16.25	1U226335162	486	19.125	1U227335162
	3 x 1-1/2	12.7	1/2	300	11.8125	1U389035162	402	15.8125	1U217935162	605	23.8125	1U389335162
		19.1	3/4	372	14.625	1U226535162	483	19	1L400135162	---	---	---
4 x 2	12.7	1/2	311	12.25	1K586935162	413	16.25	1U226335162	614	24.1875	1U226435162	
	19.1	3/4	372	14.625	1U226535162	483	19	1L400135162	---	---	---	
6 x 2-1/2	12.7	1/2	321	12.625	1U230535162	421	16.5625	1U230635162	624	24.5625	1U230735162	
	19.1	3/4	381	15	1U230835162	502	19.75	1U444635162	681	26.8125	1U232335162	

1. 667 actuator.
2. 657 or 585C Size 60-130 actuator.

Key 7* Valve Plug Stem for Bellows Seal Bonnet, 316 stainless steel

VALVE SIZE, NPS		STEM DIA. & VSC SIZE		STEM LENGTH		PART NUMBER
ES	EAS	mm	Inches	mm	Inches	
1/2, 3/4, 1, 1-1/4, 1-1/2, or 1-1/2 x 1	1, 2, or 2 x 1	9.5	3/8	222	8.75	1R288535162
		12.7	1/2	286	11.25	1R288835162
2, 2-1/2, 2-1/2 x 1-1/2, or 3	3 or 4	12.7	1/2	314	12.375	1U389235162
---	3 x 1-1/2	12.7	1/2	295	11.625	1U388935162
2 x 1 or 3 x 2	4 x 2	12.7	1/2	305	12	1U389135162
4	6	12.7	1/2	327	12.875	2R369335162
		19.1	3/4	387	15.25	1K587635162
4 x 2-1/2	6 x 2-1/2	12.7	1/2	327	12.875	2R369335072
		19.1	3/4	375	14.75	1U389435162
6	---	19.1	3/4	387	15.25	1K587635162

Key 9* Metal-Seat Seat Ring (not for Whisper Trim III Cage)

VALVE SIZE, NPS		13Cr 400-Series Stainless Steel	316 SST	R30006
ES	EAS			
1, 1-1/4 or 2 x 1	1	1U222546172	1U222535072	1U222539102
1-1/2 x 1	2 x 1	1U222046172	1U222035072	1U222039102
1-1/2 or 2-1/2 x 1-1/2	2 or 3 x 1-1/2	1U221946172	1U221935072	1U221939102
2 or 3 x 2	4 x 2	1U222646172	1U222635072	1U222639102
2-1/2 or 4 x 2-1/2	3 or 6 x 2-1/2	1U222746172	1U222735072	1U222739102
3	4	1U222846172	1U222835072	1U222839102
		1U222946172	1U222933092	1U222939102
		1U508046172	1U508033092	1U508039102
4	6	---	---	---
6	---	20A3260X012	20A3260X022	20A3260X152
8	---	---	---	---

Key 9* Fisher EAS Liner

Liner Material	Valve Size, NPS	CL150 Raised Face	CL300 Raised Face	CL600 Raised Face	Socket Weld	Schedule 40 or 80 Butt Weld
416 SST (hardened)	1	1V560146172	1U384246172	1V560246172	1V560146172	1V560146172
	2	1V560346172	1U384346172	1V560546172	1V560346172	1V560346172
	2 x 1	1V560646172	1U385146172	1V387646172	1V560646172	1V560646172
	3	2V561346172	2U384546172	2V561646172	---	2V561346172
	3 x 1-1/2	2V560946172	2U385346172	2V545946172	---	2V560946172
	4	2V562246172	2U384746172	2V561946172	---	2V562246172
	4 x 2	2V561846172	2U385546172	2V561246172	---	2V561846172
316 SST	6	2V563146172	2U384946172	2V562846172	---	2U384946172
	6 x 2-1/2	2V562646172	2U385746172	2V562346172	---	2U385746172
	1	1V560135072	1U384235072	1V560235072	1V560135072	1V560135072
	2	1V560335072	1U384335072	1V560535072	1V560335072	1V560335072
	2 x 1	1V560535072	1U385135072	1V387635072	1V560635072	1V560635072
	3	2V561335072	2U384535072	2V561635072	---	2V561335072
	3 x 1-1/2	2V560935072	2U385335072	2V545935072	---	2V560935072
4 x 2	4	2V562235072	2U384735072	2V561935072	---	2V562235072
	6	2V561835072	2U385535072	2V561235072	---	2V561835072
	6	2V563135072	2U384935072	2V562835072	---	2U384935072
	6 x 2-1/2	2V562635072	2U385735072	2V562335072	---	2U385735072

Key 9* Whisper Trim III Seat Ring (NPS 6 Fisher ES only)

13Cr 400-Series Stainless Steel	316 SST	316 SST w/CoCr-A
21A9794X012	21A9794X022	21A9795X012

Key 9* Seat Ring, Micro-Flow and Micro-Flute Cage

ORIFICE SIZE, INCHES	VALVE SIZE, NPS		
	ES-1/2, 3/4, 1, 1-1/4	ES-1-1/2, EAS-2	ES-2
13Cr 400-Series Stainless Steel			
0.1875 ⁽¹⁾	1V108346172	1V108446172	1V108546172
0.25	1U285246172	1U285746172	1U286246172
0.375	1U285346172	1U285846172	1U286346172
0.5	1U285446172	1U285946172	1U286446172
0.75	1U2855X0342	1U286046172	1U286546172
1	1U2856X0242	1U286146172	1U286646172
316 SST			
0.1875 ⁽¹⁾	1V108335072	1V108435072	1V108535072
0.25	13A5872X012	1U285735072	1U286235072
0.375	13A5873X012	1U285835072	1U286335072
0.5	1U285435072	1U285935072	1U286435072
0.75	1U2855X0332	1U286035072	1U286535072
1	1U2856X0232	1U286135072	1U286635072
316 SST with CoCr-A Seat			
0.1875 ⁽¹⁾	2V626250332	20A0140X012	20A0141X012
0.25	2U855946052	2U856446052	2U856946052
0.375	2U856046052	2U856546052	2U857046052
0.5	2U856146052	2U856646052	2U857146052
0.75	2U8562X0192	2U856746052	2U857246052
1	2U8563X0092	2U856846052	2U857346052

1. Micro-Flow cage only.

Gasket Descriptions

KEY NUMBER	DESCRIPTION	MATERIAL
		FGM -198° to 593°C (-325° to 1100°F)
10	Bonnet Gasket	Graphite/S31600
11	Cage Gasket	
13	Seat Ring or Liner Gasket	
14 or 20	Adapter Gasket	
12	Spiral Wound Gasket	N06600/Graphite
27 or 51	Shim	S31600

Keys 10*, 11*, 12*, 13*, 14*, 20*, 27*, and 51* Gaskets and Shims

VALVE SIZE, NPS		KEY NUMBER	To 593°C (To 1100°F)	VALVE SIZE, NPS		KEY NUMBER	To 593°C (To 1100°F)
ES	EAS			ES	EAS		
1/2, 3/4, 1 or 1-1/4	1	Set ⁽¹⁾ 10 12 13 27 or 51	RGASKETX162 1R2859X0042 1R286099442 1R2862X0062 16A1936X012	3	4	Set ⁽¹⁾ 10 12 13 27 or 51	RGASKETX202 1R3484X0042 1R348299442 1R3481X0052 16A1940X012
1-1/2	2	Set ⁽¹⁾ 10 12 13 27 or 51	RGASKETX172 1R3101X0032 1R309999442 1R3098X0052 16A1937X012	3 x 2	4 x 2	Set ⁽¹⁾ 10 11 12 13 14 27 or 51	RGASKETX272 1R3484X0042 1R3298X0032 1R329799442 1R3296X0042 1R3481X0052 16A1938X012
1-1/2 x 1	2 x 1	Set ⁽¹⁾ 10 11 12 13 20 27 or 51	RGASKETX242 1R3101X0032 1R2861X0042 1R286099442 1R3098X0052 1U2152X0042 16A1936X012			4	6
2	---	Set 10 12 13 51	RGASKETX182 1R3299X0042 1R329799442 1R3296X0042 16A1938X012	4 x 2-1/2	6 x 2-1/2	Set ⁽¹⁾ 10 11 12 13 14 27 or 51	RGASKETX282 1R3724X0042 1R3846X0042 1R384599442 1R3844X0052 1J5047X0062 16A1939X012
2 x 1	---	Set 10 11 12 13 14 51	RGASKETX252 1R3299X0042 1R2861X0042 1R286099442 1R2862X0062 1R3296X0042 16A1936X012			6	---
2-1/2	3	Set ⁽¹⁾ 10 12 13 27 or 51	RGASKETX192 1R3847X0032 1R384599442 1R3844X0052 16A1939X012	8	---	Set 10 13	RGASKETX232 10A3265X112 10A3266X082
2-1/2 x 1-1/2	3 x 1-1/2	Set ⁽¹⁾ 10 11 12 13 14 27 or 51	RGASKETX262 1R3847X0032 1R3100X0032 1R309999442 1R3098X0052 1R3844X0052 16A1937X012				

1. Set number good for both ES and EAS valve body.
 2. Whisper Trim III construction requires 2 bonnet gaskets (key 10) so order a set plus 1 extra bonnet gasket for that construction.

Keys 21*, 22*, and 23* PTFE-Seat Disk Retainer, Disk Seat, and Disk

VALVE SIZE, NPS		KEY 21 DISK RETAINER, 316 SST	KEY 22 DISK SEAT		KEY 23 DISK, PTFE -73° TO 204° C (-100° TO 400° F)
ES	EAS		316 SST	CoCr-A	
1/2, 3/4, 1, 1-1/4, or 2 x 1	1	1V710035072	1V710235072	1V710239012	1V710106242
1-1/2 or 2-1/2 x 1-1/2	2 or 3 x 1-1/2	1V710335072	1V710535072	1V710539102	1V710406242
1-1/2 x 1	2 x 1	1V712135072	1V712235072	1V712239102	1V710106242
2 or 3 x 2	4 x 2	1V710835072	1V710635072	1V710639102	1V710706242
2-1/2 or 4 x 2-1/2	3	1V710935072	1V711135072	1V711139102	1V711006242
3	6 x 2-1/2	1V711235072	1V711435072	1V711439102	1V711306242
4	6	1V711533092	1V711733092	1V711739102	1V711606242
6	All except Whisper Trim III cage	1V711833092	1V712033092	1V7120X0012	1V711906242
	Whisper Trim III cage	23A4937X012	23A4938X012	---	13A4936X012
8	---	10A4446X012	20A4467X012	20A4467X022	20A4468X012

*Recommended spare parts

Fisher, easy-e, ENVIRO-SEAL, WhisperFlo, and Whisper Trim are marks owned by one of the companies in the Emerson Process Management business division of Emerson Electric Co. Emerson Process Management, Emerson, and the Emerson logo are trademarks and service marks of Emerson Electric Co. All other marks are the property of their respective owners.

The contents of this publication are presented for informational purposes only, and while every effort has been made to ensure their accuracy, they are not to be construed as warranties or guarantees, express or implied, regarding the products or services described herein or their use or applicability. All sales are governed by our terms and conditions, which are available upon request. We reserve the right to modify or improve the designs or specifications of such products at any time without notice. Neither Emerson, Emerson Process Management, nor any of their affiliated entities assumes responsibility for the selection, use or maintenance of any product. Responsibility for proper selection, use, and maintenance of any product remains solely with the purchaser and end user.

Emerson Process Management
 Marshalltown, Iowa 50158 USA
 Sorocaba, 18087 Brazil
 Chatham, Kent ME4 4QZ UK
 Dubai, United Arab Emirates
 Singapore 128461 Singapore

www.Fisher.com

